



*Waar je
elkaar
ontmoet*



Project De Waag

120 appartementen



Inhoud

Overzicht woningen - advertentie 1	2
Overzicht bergingen en oppervlakten	3
Nieheimerstraat 7	4
Nieheimerstraat 9	5
Nieheimerstraat 11	6
Nieheimerstraat 13	7
Nieheimerstraat 15	8
Nieheimerstraat 17	9
Nieheimerstraat 21	10
Nieheimerstraat 23	11
Nieheimerstraat 67	12
Nieheimerstraat 69	13
Nieheimerstraat 75	14
Nieheimerstraat 77	15
Nieheimerstraat 89	16
Nieheimerstraat 125	17
Nieheimerstraat 127	18
Nieheimerstraat 141	19
Nieheimerstraat 177	20
Nieheimerstraat 179	21

Woningadvertentie 1

18 tweekamerappartementen van 50 - 53 m² met een netto huurprijs van € 650,43 (prijspeil 2024, excl. servicekosten)

In de onderstaande tabel vindt u de adressen die beschikbaar worden gesteld in woningadvertentie 1.

Het gaat hier om 18 tweekamerappartementen met een netto huurprijs van € 650,43, op basis van het prijspeil 2024.

Aan de hand van de tabel leest u gemakkelijk de belangrijkste kenmerken per adres:

Adres	Bouwnr.	Type	Verdieping	Opper- vlakte	Woonkamer / keuken	Slaap- kamer	Bad- kamer	Apart toilet?	Buiten ruimte	Zonne- panelen
Nieheimerstraat 7	002	K2.0a	begane grond	53,0 m ²	24,3 m ²	12,6 m ²	3,5 m ²	Ja	Terras	3
Nieheimerstraat 9	003	K1.0a	begane grond	50,5 m ²	19,2 m ²	13,1 m ²	4,3 m ²	Nee	Terras	3
Nieheimerstraat 11	004	K1.1a sp	begane grond	50,0 m ²	19,2 m ²	12,9 m ²	4,3 m ²	Nee	Terras	3
Nieheimerstraat 13	005	K1.1a	begane grond	50,0 m ²	19,2 m ²	12,9 m ²	4,3 m ²	Nee	Terras	3
Nieheimerstraat 15	006	K1.2a	begane grond	50,0 m ²	19,2 m ²	12,9 m ²	4,3 m ²	Nee	Terras	3
Nieheimerstraat 17	007	K1.3a	begane grond	50,0 m ²	19,2 m ²	12,9 m ²	4,3 m ²	Nee	Terras	3
Nieheimerstraat 21	009	K2.0b	1e verdieping	53,0 m ²	24,3 m ²	12,6 m ²	3,5 m ²	Ja	Balkon	3
Nieheimerstraat 23	010	K1.0b	1e verdieping	50,5 m ²	19,2 m ²	13,1 m ²	4,3 m ²	Nee	Balkon	3
Nieheimerstraat 67	032	K1.6a	1e verdieping	50,2 m ²	19,2 m ²	12,9 m ²	4,3 m ²	Nee	Balkon	3
Nieheimerstraat 69	033	K1.6a sp	1e verdieping	50,2 m ²	19,2 m ²	12,9 m ²	4,3 m ²	Nee	Balkon	3
Nieheimerstraat 75	036	K2.0b	2e verdieping	53,0 m ²	24,3 m ²	12,6 m ²	3,5 m ²	Ja	Balkon	3
Nieheimerstraat 77	037	K1.0b	2e verdieping	50,5 m ²	19,2 m ²	13,1 m ²	4,3 m ²	Nee	Balkon	3
Nieheimerstraat 89	043	K1.5a	2e verdieping	49,7 m ²	19,2 m ²	13,3 m ²	4,3 m ²	Nee	Balkon	3
Nieheimerstraat 125	061	K1.6b	2e verdieping	50,2 m ²	19,2 m ²	12,9 m ²	4,3 m ²	Nee	Balkon	3
Nieheimerstraat 127	062	K1.6b sp	2e verdieping	50,2 m ²	19,2 m ²	12,9 m ²	4,3 m ²	Nee	Balkon	3
Nieheimerstraat 141	069	K1.5b	3e verdieping	49,7 m ²	19,2 m ²	13,3 m ²	4,3 m ²	Nee	Balkon	3
Nieheimerstraat 177	087	K1.6b	3e verdieping	50,2 m ²	19,2 m ²	12,9 m ²	4,3 m ²	Nee	Balkon	3
Nieheimerstraat 179	088	K1.6b sp	3e verdieping	50,2 m ²	19,2 m ²	12,9 m ²	4,3 m ²	Nee	Balkon	3

Voor deze advertentie gelden de onderstaande voorrangsregels:

- Er geldt lokale voorrang, voor inwoners van de Gemeente Woerden;
- Er geldt voorrang voor woningzoekenden met een urgentie;
- Er geldt voorrang voor woningzoekenden waarbij voorrang Van Groot naar Beter is toegekend door Cazas Wonen;
- Er geldt voorrang voor woningzoekenden met een laag inkomen.

Voor meer informatie verwijzen wij u graag naar bladzijde 6 van de verhuurbrochure.

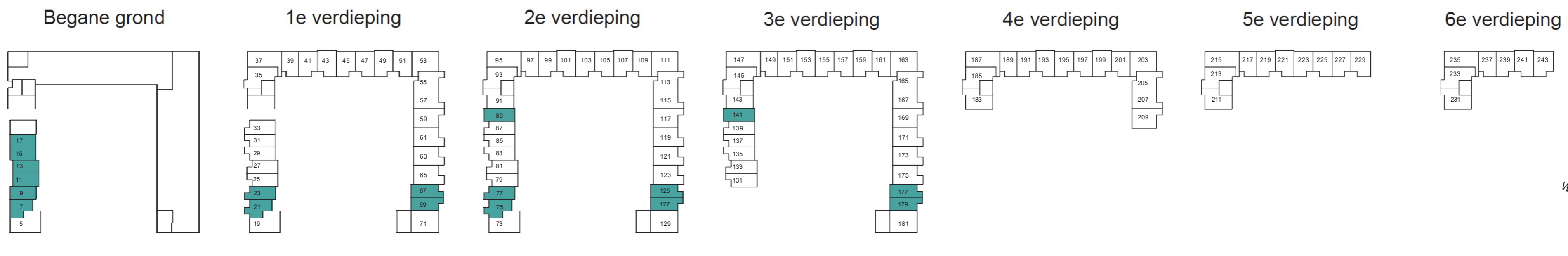

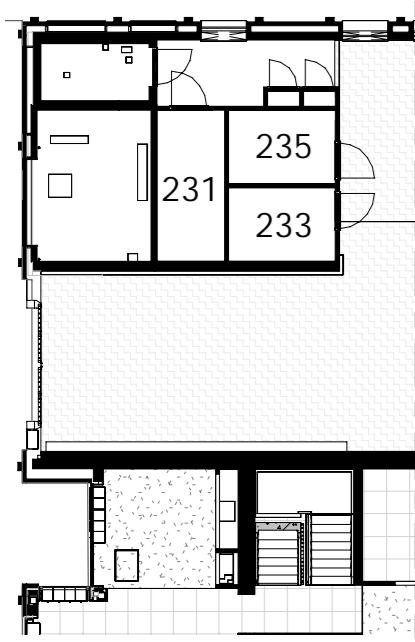

60

Overzicht bergingen

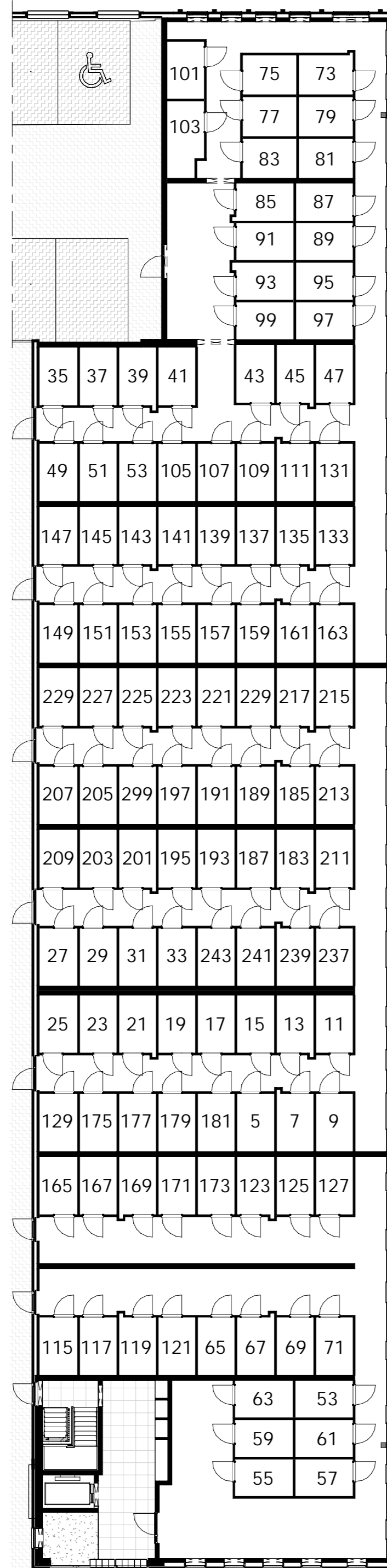

Overzicht m² GO					
Verdieping	Bouwdeel	Bouwnummer	Huisnummer	Woningtype	GO (m²)
00 begane grond	A	001	5	G1.0	66.4 m²
00 begane grond	A	002	7	K2.0a	53.0 m²
00 begane grond	A	003	9	K1.0a	50.5 m²
00 begane grond	A	004	11	K1.1a sp	50.0 m²
00 begane grond	A	005	13	K1.1a	50.0 m²
00 begane grond	A	006	15	K1.2a	50.0 m²
00 begane grond	A	007	17	K1.3a	50.0 m²
01 eerste verdieping	A	008	19	G1.1	66.4 m²
01 eerste verdieping	A	009	21	K2.0b	53.0 m²
01 eerste verdieping	A	010	23	K1.0b	50.5 m²
01 eerste verdieping	A	011	25	K1.1b sp	50.0 m²
01 eerste verdieping	A	012	27	K1.1b	50.0 m²
01 eerste verdieping	A	013	29	K1.2b	50.0 m²
01 eerste verdieping	A	014	31	K1.3b	50.0 m²
01 eerste verdieping	A	015	33	K1.4a	50.0 m²
01 eerste verdieping	B	016	35	M2.1a	65.6 m²
01 eerste verdieping	B	017	37	M2.2a	66.4 m²
01 eerste verdieping	B	018	39	M2.3a	65.9 m²
01 eerste verdieping	B	019	41	M2.4a	65.9 m²
01 eerste verdieping	B	020	43	M3.1a	69.7 m²
01 eerste verdieping	B	021	45	M2.5a	65.9 m²
01 eerste verdieping	C	022	47	M2.6a	66.1 m²
01 eerste verdieping	C	023	49	M2.7a	69.9 m²
01 eerste verdieping	C	024	51	M2.8a	66.1 m²
01 eerste verdieping	C	025	53	M2.9a	69.0 m²
01 eerste verdieping	C	026	55	M2.10a	65.6 m²
01 eerste verdieping	C	027	57	G2.1a	70.6 m²
01 eerste verdieping	C	028	59	G2.2a	70.6 m²
01 eerste verdieping	D	029	61	G2.3a	70.7 m²
01 eerste verdieping	D	030	63	G2.4a	70.7 m²
01 eerste verdieping	D	031	65	G2.5a	70.7 m²
01 eerste verdieping	D	032	67	K1.6a	50.2 m²
01 eerste verdieping	D	033	69	K1.6a sp	50.2 m²
01 eerste verdieping	D	034	71	G3.1a	77.8 m²
02 tweede verdieping	A	035	73	G1.2	66.4 m²
02 tweede verdieping	A	036	75	K2.0b	53.0 m²
02 tweede verdieping	A	037	77	K1.0b	50.5 m²
02 tweede verdieping	A	038	79	K1.1b sp	50.0 m²
02 tweede verdieping	A	039	81	K1.1b	50.0 m²
02 tweede verdieping	A	040	83	K1.2b	50.0 m²
02 tweede verdieping	A	041	85	K1.3b	50.0 m²
02 tweede verdieping	A	042	87	K1.4a	50.0 m²
02 tweede verdieping	A	043	89	K1.5a	49.7 m²
02 tweede verdieping	B	044	91	M1.1	61.9 m²
02 tweede verdieping	B	045	93	M2.1b	65.6 m²
02 tweede verdieping	B	046	95	M2.2b	66.4 m²
02 tweede verdieping	B	047	97	M2.3b	65.9 m²
02 tweede verdieping	B	048	99	M2.4b	65.9 m²
02 tweede verdieping	B	049	101	M3.1b	69.7 m²
02 tweede verdieping	B	050	103	M2.5b	65.9 m²
02 tweede verdieping	C	051	105	M2.6b	66.1 m²
02 tweede verdieping	C	052	107	M2.7b	69.9 m²
02 tweede verdieping	C	053	109	M2.8b	66.1 m²
02 tweede verdieping	C	054	111	M2.9b	69.0 m²
02 tweede verdieping	C	055	113	M2.10b	65.6 m²
02 tweede verdieping	C	056	115	G2.1b	70.6 m²
02 tweede verdieping	C	057	117	G2.2b	70.6 m²
02 tweede verdieping	D	058	119	G2.3b	70.7 m²

Overzicht m² GO					
Verdieping	Bouwdeel	Bouwnummer	Huisnummer	Woningtype	GO (m²)
02 tweede verdieping	D	059	121	G2.4b	70.7 m²
02 tweede verdieping	D	060	123	G2.5b	70.7 m²
02 tweede verdieping	D	061	125	K1.6b	50.2 m²
02 tweede verdieping	D	062	127	K1.6b sp	50.2 m²
02 tweede verdieping	D	063	129	G3.1a	77.8 m²
03 derde verdieping	A	064	131	K1.1c	50.0 m²
03 derde verdieping	A	065	133	K1.1b	50.0 m²
03 derde verdieping	A	066	135	K1.2b	50.0 m²
03 derde verdieping	A	067	137	K1.3b	50.0 m²
03 derde verdieping	A	068	139	K1.4a	50.0 m²
03 derde verdieping	A	069	141	K1.5b	49.7 m²
03 derde verdieping	B	070	143	M1.1	61.9 m²
03 derde verdieping	B	071	145	M2.1b	65.6 m²
03 derde verdieping	B	072	147	M2.2b	66.4 m²
03 derde verdieping	B	073	149	M2.3b	65.9 m²
03 derde verdieping	B	074	151	M2.4b	65.9 m²
03 derde verdieping	B	075	153	M3.1b	69.7 m²
03 derde verdieping	B	076	155	M2.5b	65.9 m²
03 derde verdieping	C	077	157	M2.6b	66.1 m²
03 derde verdieping	C	078	159	M2.7b	69.9 m²
03 derde verdieping	C	079	161	M2.8b	66.1 m²
03 derde verdieping	C	080	163	M2.9b	69.0 m²
03 derde verdieping	C	081	165	M2.10b	65.6 m²
03 derde verdieping	C	082	167	G2.1b	70.6 m²
03 derde verdieping	C	083	169	G2.2b	70.6 m²
03 derde verdieping	D	084	171	G2.3b	70.7 m²
03 derde verdieping	D	085	173	G2.4b	70.7 m²
03 derde verdieping	D	086	175	G2.5b	70.7 m²
03 derde verdieping	D	087	177	K1.6b	50.2 m²
03 derde verdieping	D	088	179	K1.6b sp	50.2 m²
03 derde verdieping	D	089	181	G3.1a	77.8 m²
04 vierde verdieping	B	090	183	M1.1	61.9 m²
04 vierde verdieping	B	091	185	M2.1b	65.6 m²
04 vierde verdieping	B	092	187	M2.2b	66.4 m²
04 vierde verdieping	B	093	189	M2.3b	65.9 m²
04 vierde verdieping	B	094	191	M2.4b	65.9 m²
04 vierde verdieping	B	095	193	M3.1b	69.7 m²
04 vierde verdieping	B	096	195	M2.5b	65.9 m²
04 vierde verdieping	C	097	197	M2.6b	66.1 m²
04 vierde verdieping	C	098	199	M2.7b	69.9 m²
04 vierde verdieping	C	099	201	M2.8b	66.1 m²
04 vierde verdieping	C	100	203	M2.9b	69.0 m²
04 vierde verdieping	C	101	205	M2.10b	65.6 m²
04 vierde verdieping	C	102	207	G2.1b	70.6 m²
04 vierde verdieping	C	103	209	G2.2b	70.6 m²
05 vijfde verdieping	B	104	211	M1.1	61.9 m²
05 vijfde verdieping	B	105	213	M2.1b	65.6 m²
05 vijfde verdieping	B	106	215	M2.2b	66.4 m²
05 vijfde verdieping	B	107	217	M2.3b	65.9 m²
05 vijfde verdieping	B	108	219	M2.4b	65.9 m²
05 vijfde verdieping	B	109	221	M3.1b	69.7 m²
05 vijfde verdieping	B	110	223	M2.5b	65.9 m²
05 vijfde verdieping	C	111	225	M2.6b	66.1 m²
05 vijfde verdieping	C	112	227	M2.7b	66.1 m²
05 vijfde verdieping	C	113	229	M2.8b	66.1 m²
06 zesde verdieping	B	114	231	M1.1	61.9 m²
06 zesde verdieping	B	115	233	M2.1b	65.6 m²
06 zesde verdieping	B	116	235	M2.2b	66.4 m²
06 zesde verdieping	B	117	237	M2.3b	65.9 m²
06 zesde verdieping	B	118	239	M3.1b	69.7 m²
06 zesde verdieping	B	119	241	M3.1b	69.7 m²
06 zesde verdieping	B	120	243	M2.5b	65.9 m²

Totaal: 120 7545.5 m²

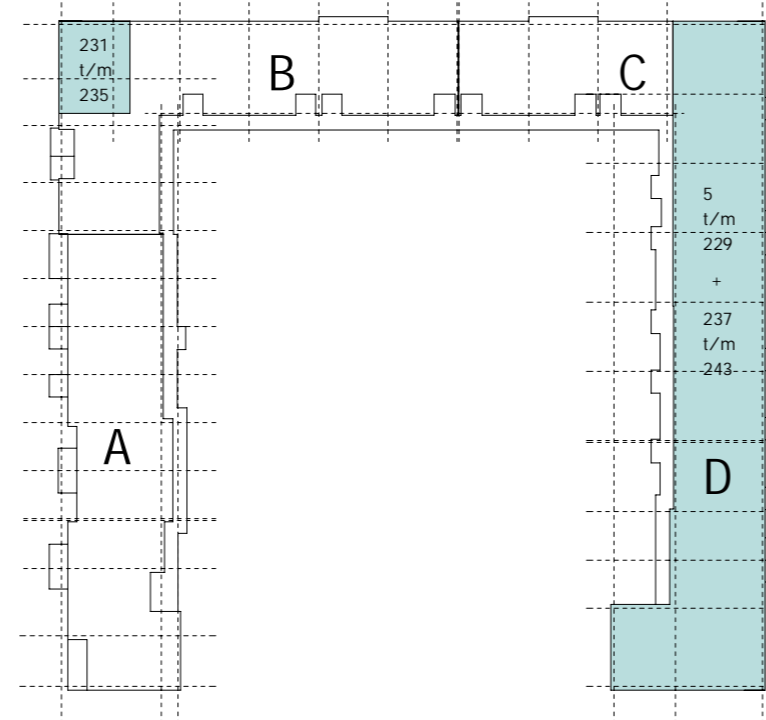

WUZZING	DATUM	GETEKEND	OMSCHRIJVING
REVIIT-LINKS	DATUM	MODELNAAM	
CONSTRUCTIEMODEL:	15-02-2024	CAZ_GDV_CON_01_UO_G106974_R22	
INSTALLATIEMODEL:	15-02-2024	CAZ_BRHW_INS-W_01_DO_G106974_R22	
KLUNDER ARCHITECTEN	PROJECT	: 120 Appartementen Woerden Snellerpoort B1 "DE WAAG"	
POSTBUS 4150			
3006 AD ROTTERDAM	OPDRACHTGEVER	: Cazas Wonen Heijmans	
K.P. VAN DER MANDELELAAN 32			
T 010 24 25 310	ONDERWERP	: Uitvoeringsfase algemeen Woningtypes Overzicht types, bouw- en huisnummers	
INFO@KLUNDERARCHITECTEN.NL			
WWW.KLUNDERARCHITECTEN.NL	STATUS	: DEFINITIEF	
	FORMAAT	: A2	
SJOERD BERGHUIS	PROJECTNR.	: 221239	
ARNOLD DRIESPRONG	SCHAAL	: 1:200	
	GETEKEND	: I.S.	
	DATUM	: 19-02-2024	
	GEWIJZIGD	: -	

TEKENINGNUMMER

UO-111

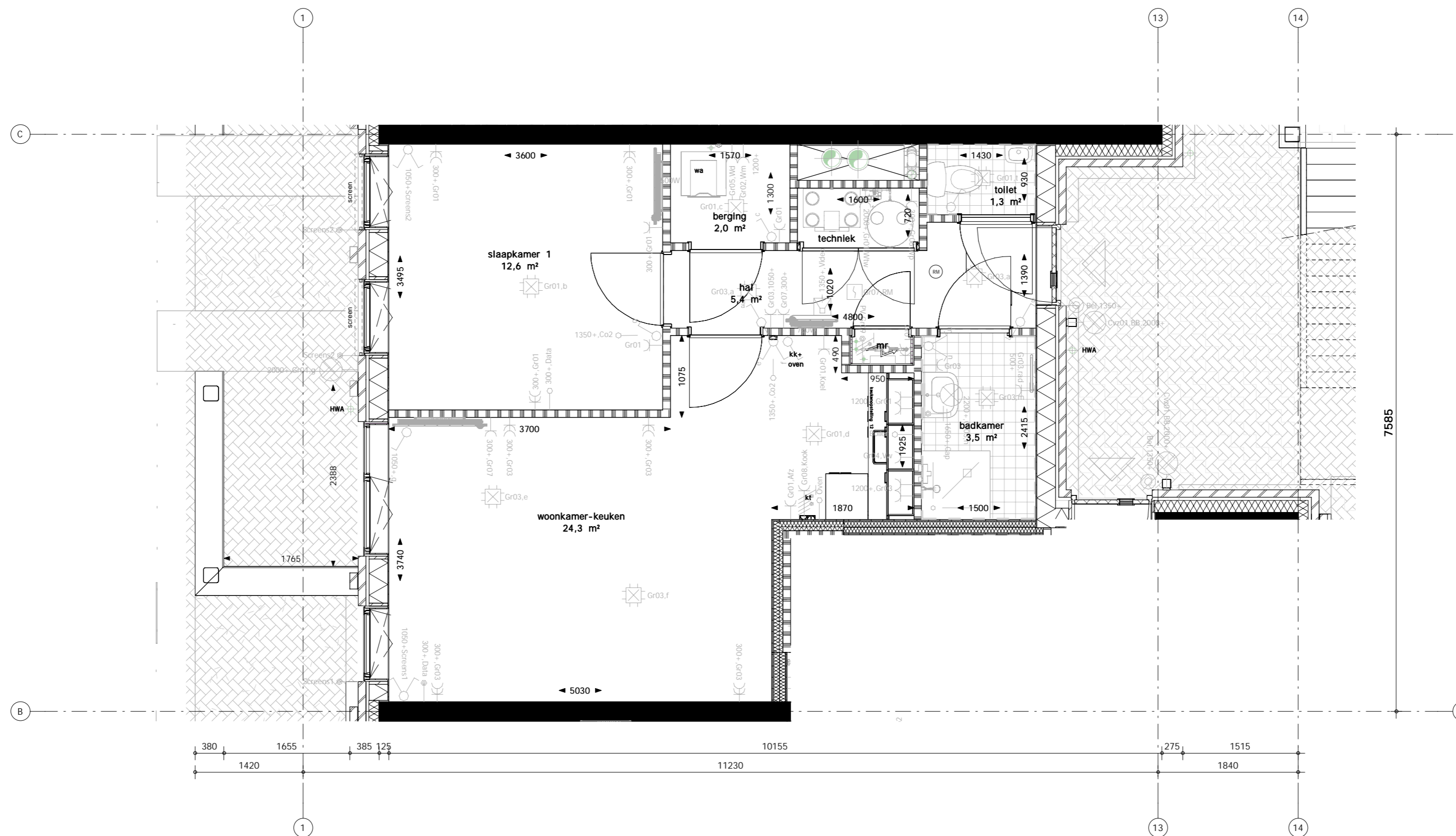

Begane grond

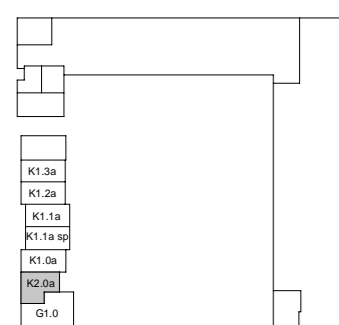

1e verdieping

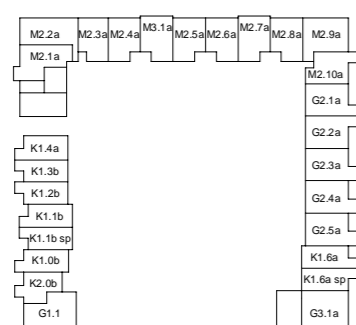

2e verdieping

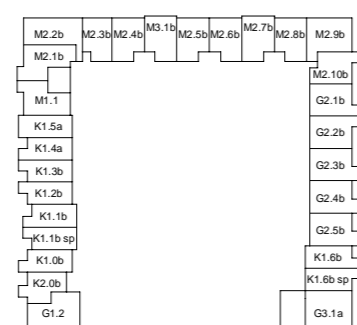

3e verdieping

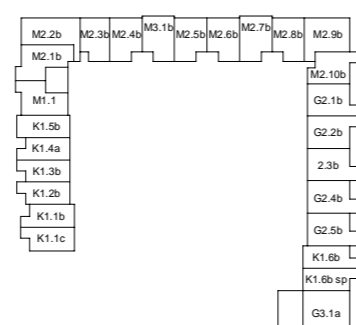

4e verdieping

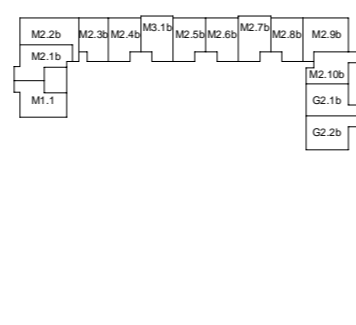

5e verdieping

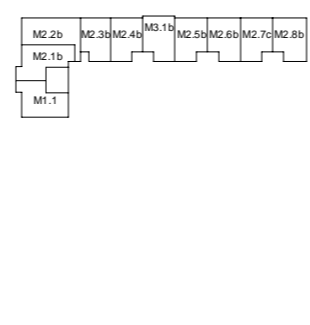

6e verdieping

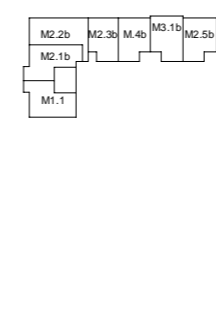

120 Appartementen Woerden Snellerpoort B1 "DE
WAAG"

Woningtype K2.0a (GO 53,0m2)

PROJECTNR. : 221239
DATUM : 19-02-2024

SCHAAL : 1:50
FORMAAT : A2
TEKENINGNUMMER : WT-18

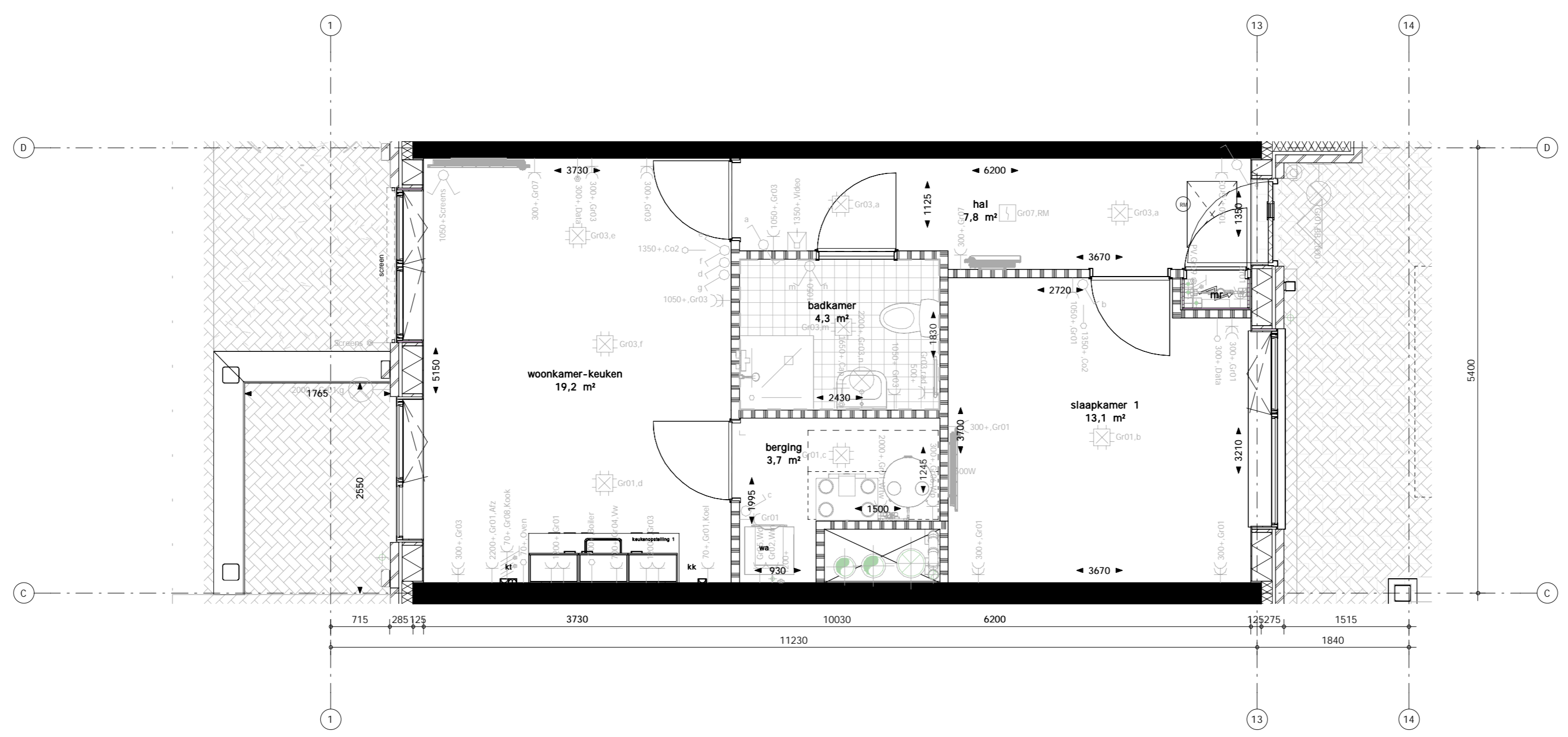

Begane grond

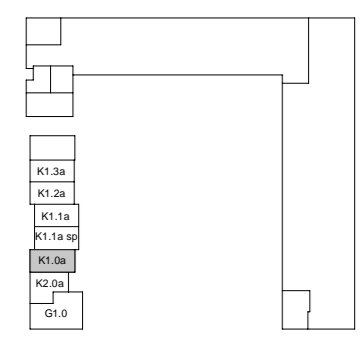

1e verdieping

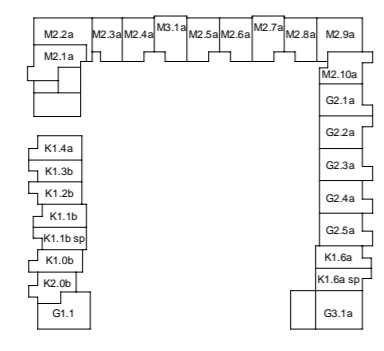

2e verdieping

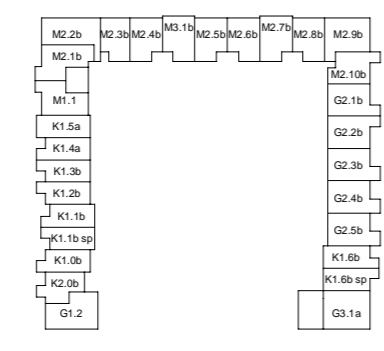

3e verdieping

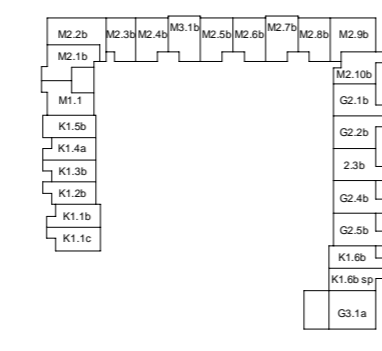

4e verdieping

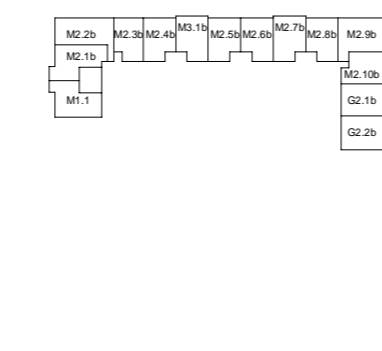

5e verdieping

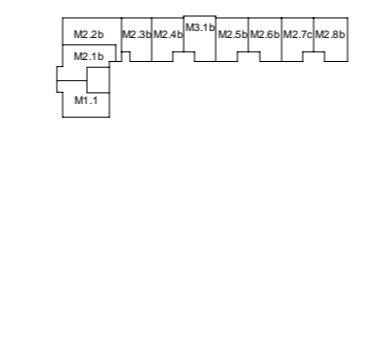

6e verdieping

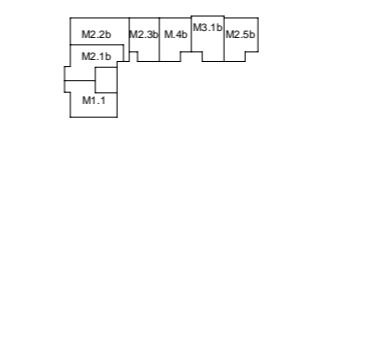

Bnr. 003

120 Appartementen Woerden Snellerpoort B1 "DE WAAG"
 Woningtype K1.0a (GO 50,5m2)
 PROJECTNR. : 221239
 DATUM : 19-02-2024
 SCHAAL : 1:50
 FORMAAT : A2
 TEKENINGNUMMER : WT-04

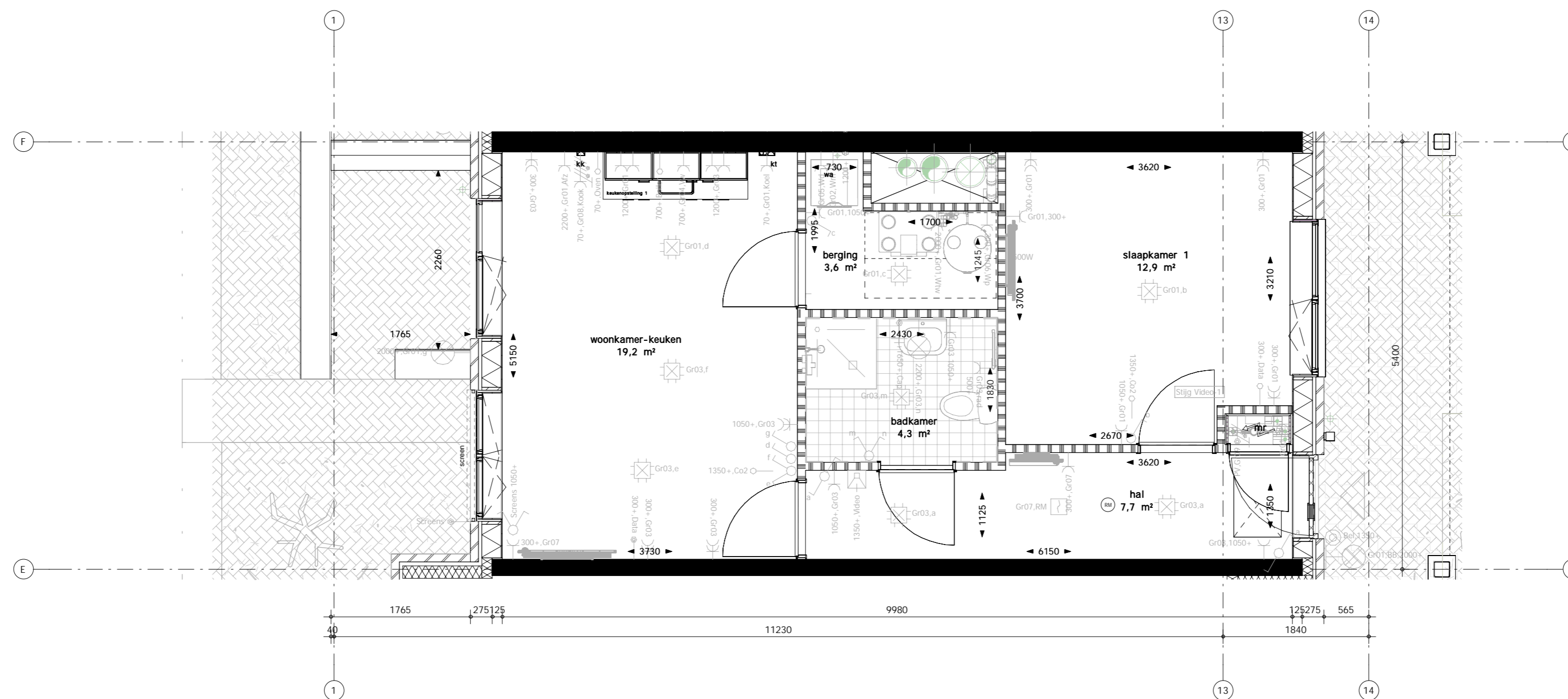

Begane grond

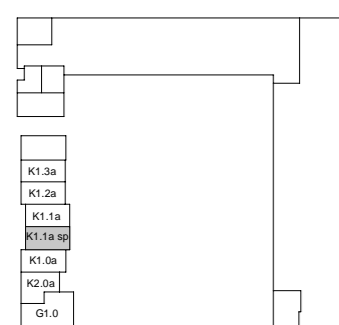

1e verdieping

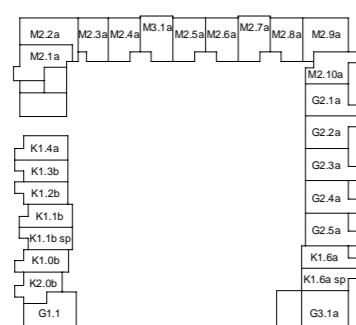

2e verdieping

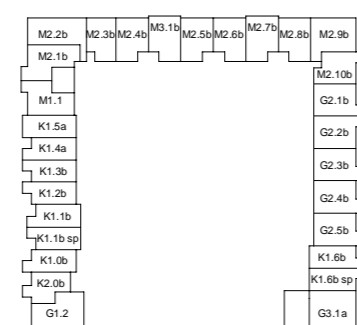

3e verdieping

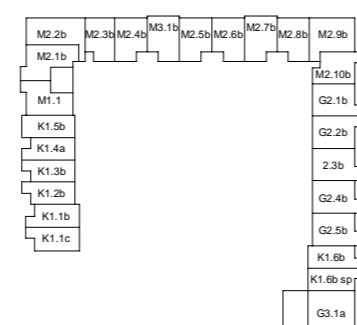

4e verdieping

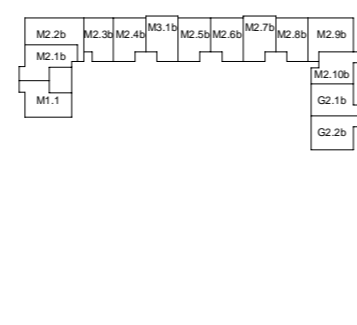

5e verdieping

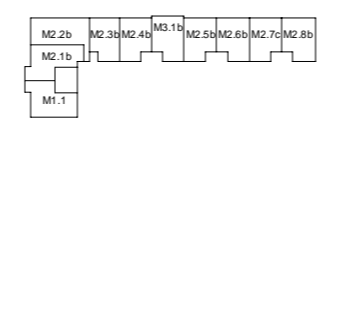

6e verdieping

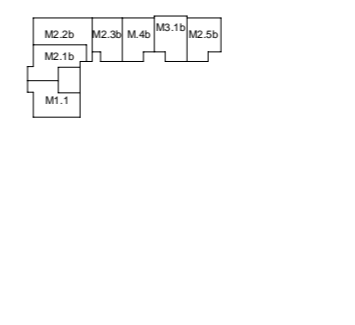

120 Appartementen Woerden Snellerpoort B1 "DE WAAG"

Woningtype K1.1asp (GO 50,0m2)

PROJECTNR. : 221239
DATUM : 19-02-2024

SCHAAL : 1:50
FORMAAT : A2
TEKENINGNUMMER : WT-07

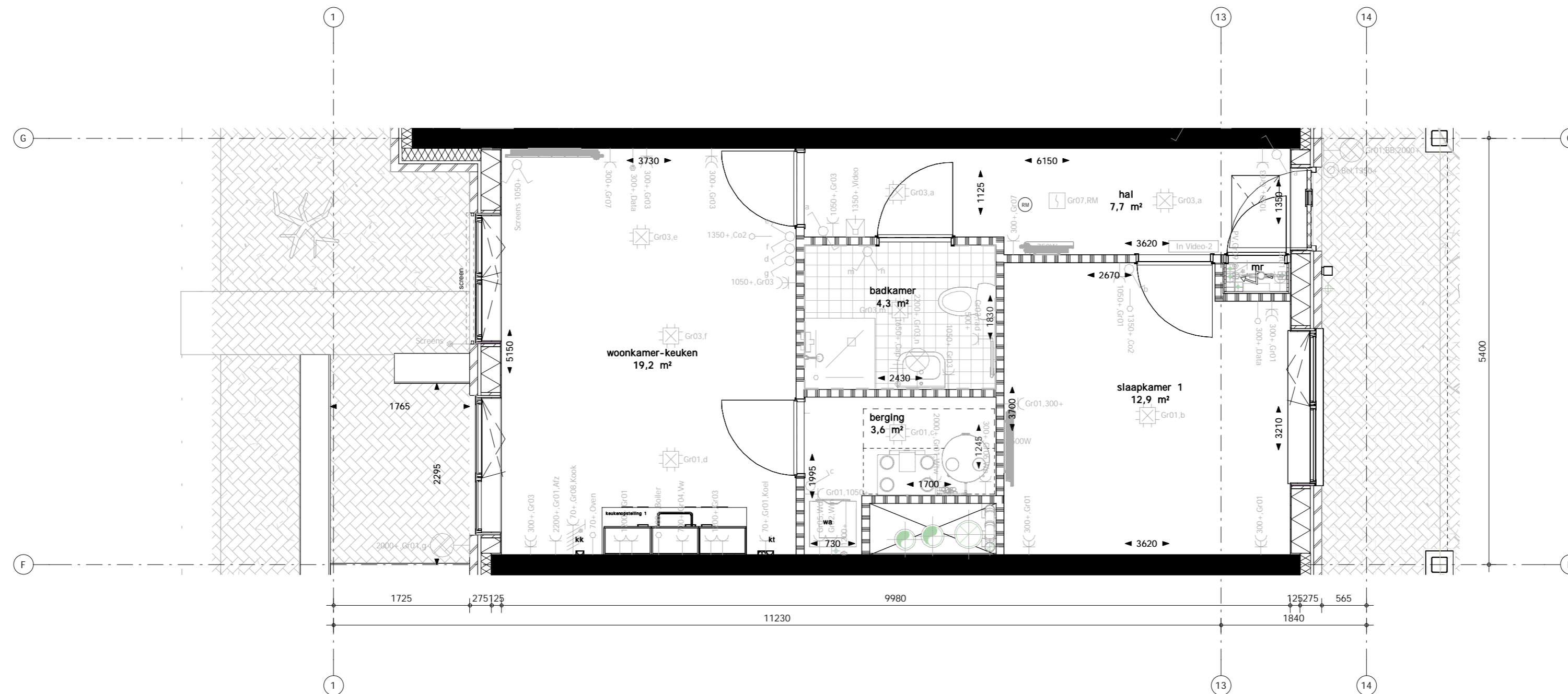

Begane grond

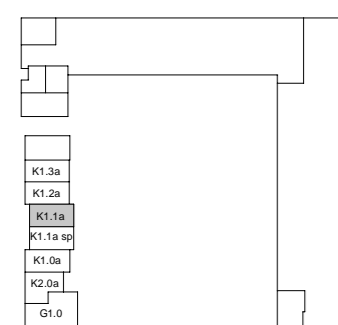

Bnr. 005

1e verdieping

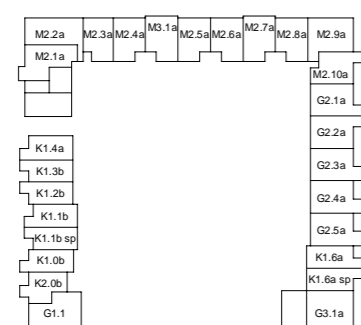

2e verdieping

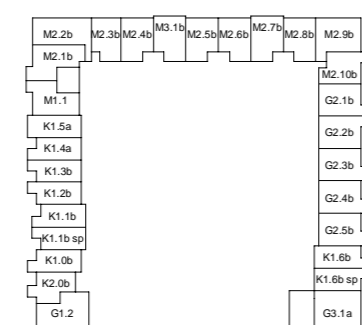

3e verdieping

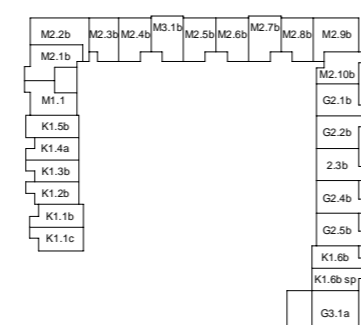

4e verdieping

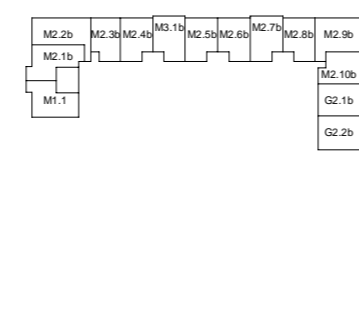

5e verdieping

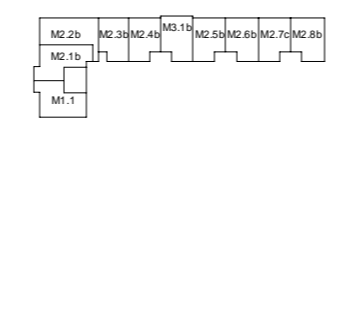

6e verdieping

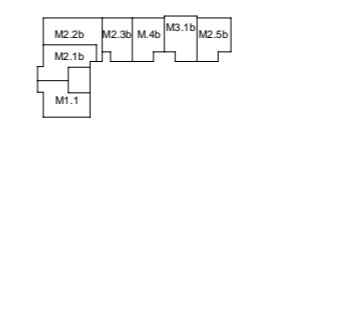

120 Appartementen Woerden Snellerpoort B1 "DE
 WAAG"

Woningtype K1.1a (GO 50,0m2)

PROJECTNR. : 221239
 DATUM : 19-02-2024

SCHAAL : 1:50
 FORMAAT : A2
 TEKENINGNUMMER : WT-06

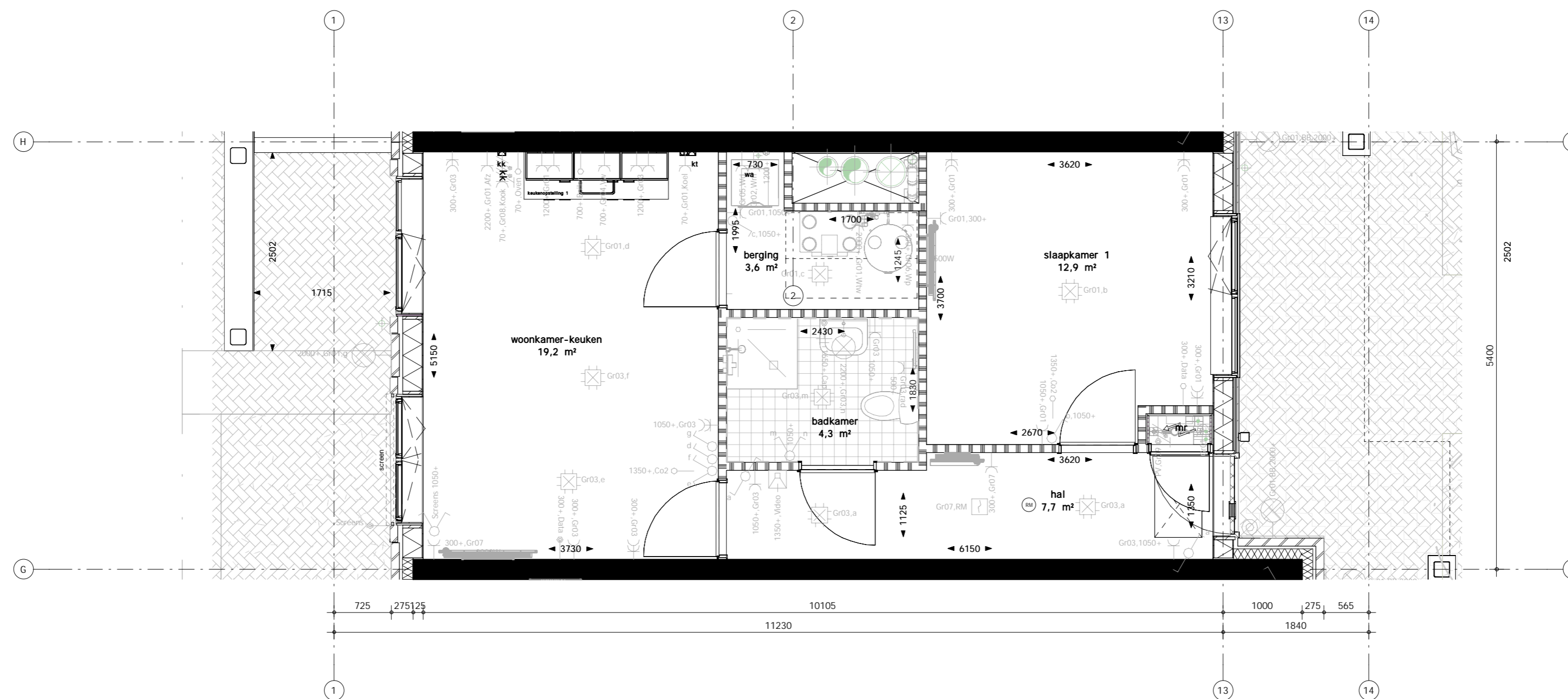

Begane grond

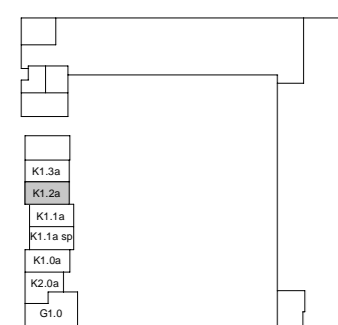

Bnr. 006

1e verdieping

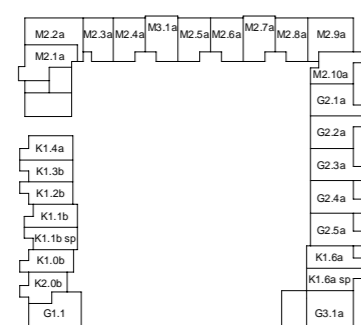

2e verdieping

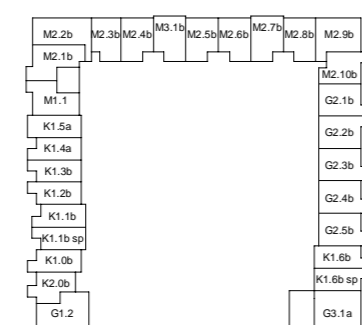

3e verdieping

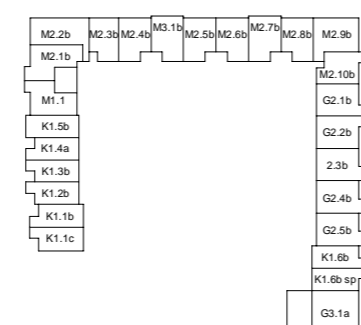

4e verdieping

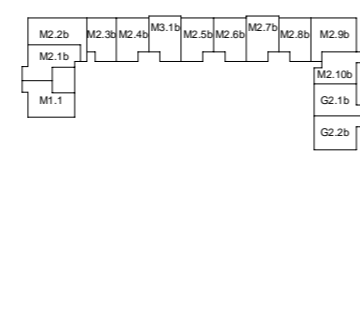

5e verdieping

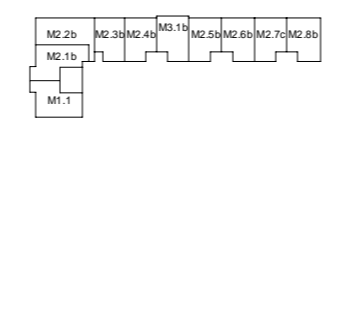

6e verdieping

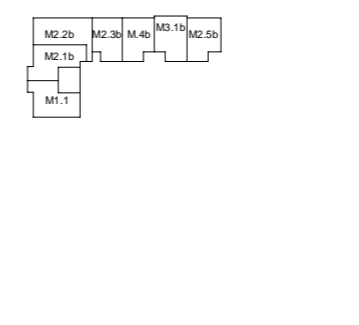

120 Appartementen Woerden Snellerpoort B1 "DE WAAG"

Woningtype K1.2a (GO 50,0m2)

PROJECTNR. : 221239
 DATUM : 19-02-2024

SCHAAL : 1:50
 FORMAAT : A2
 TEKENINGNUMMER : WT-11

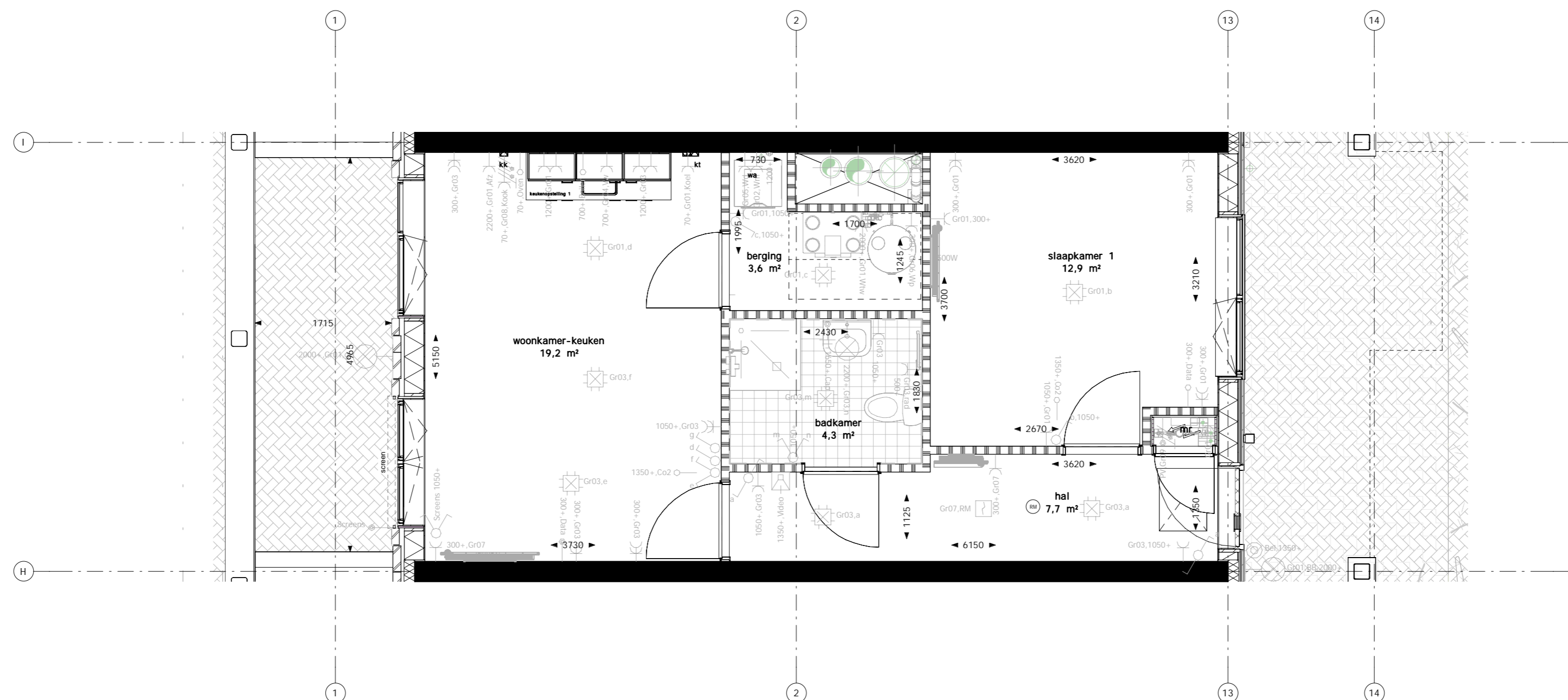

Begane grond

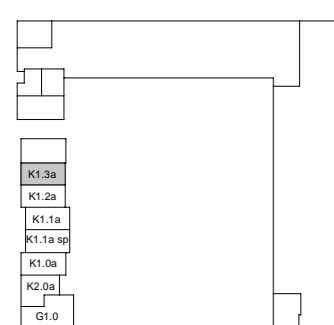

Bnr. 007

1e verdieping

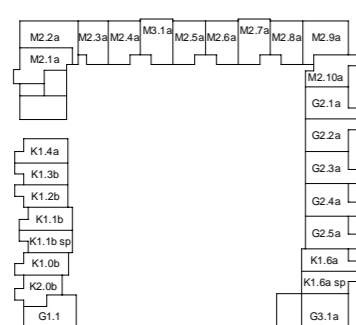

2e verdieping

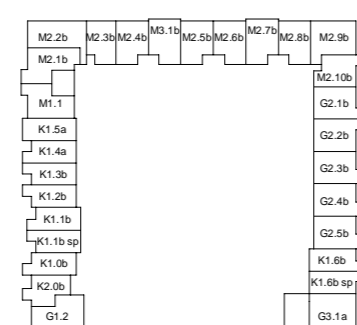

3e verdieping

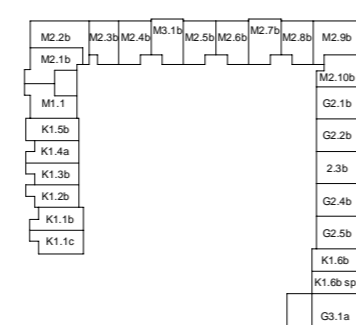

4e verdieping

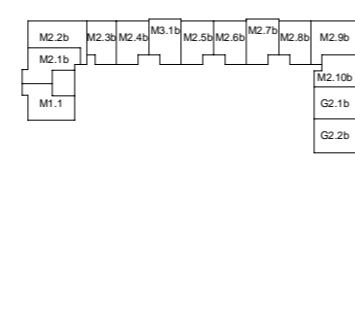

5e verdieping

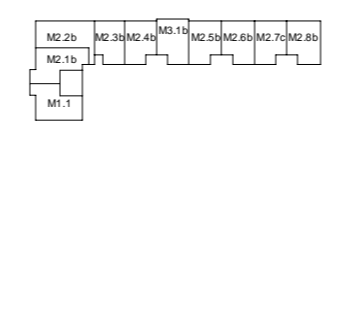

6e verdieping

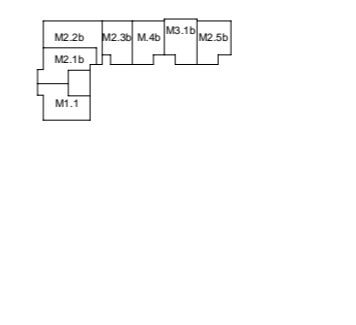

120 Appartementen Woerden Snellerpoort B1 "DE WAAG"

Woningtype K1.3a (GO 50,0m2)

PROJECTNR. : 221239
DATUM : 19-02-2024

SCHAAL : 1:50
FORMAAT : A2
TEKENINGNUMMER : WT-13

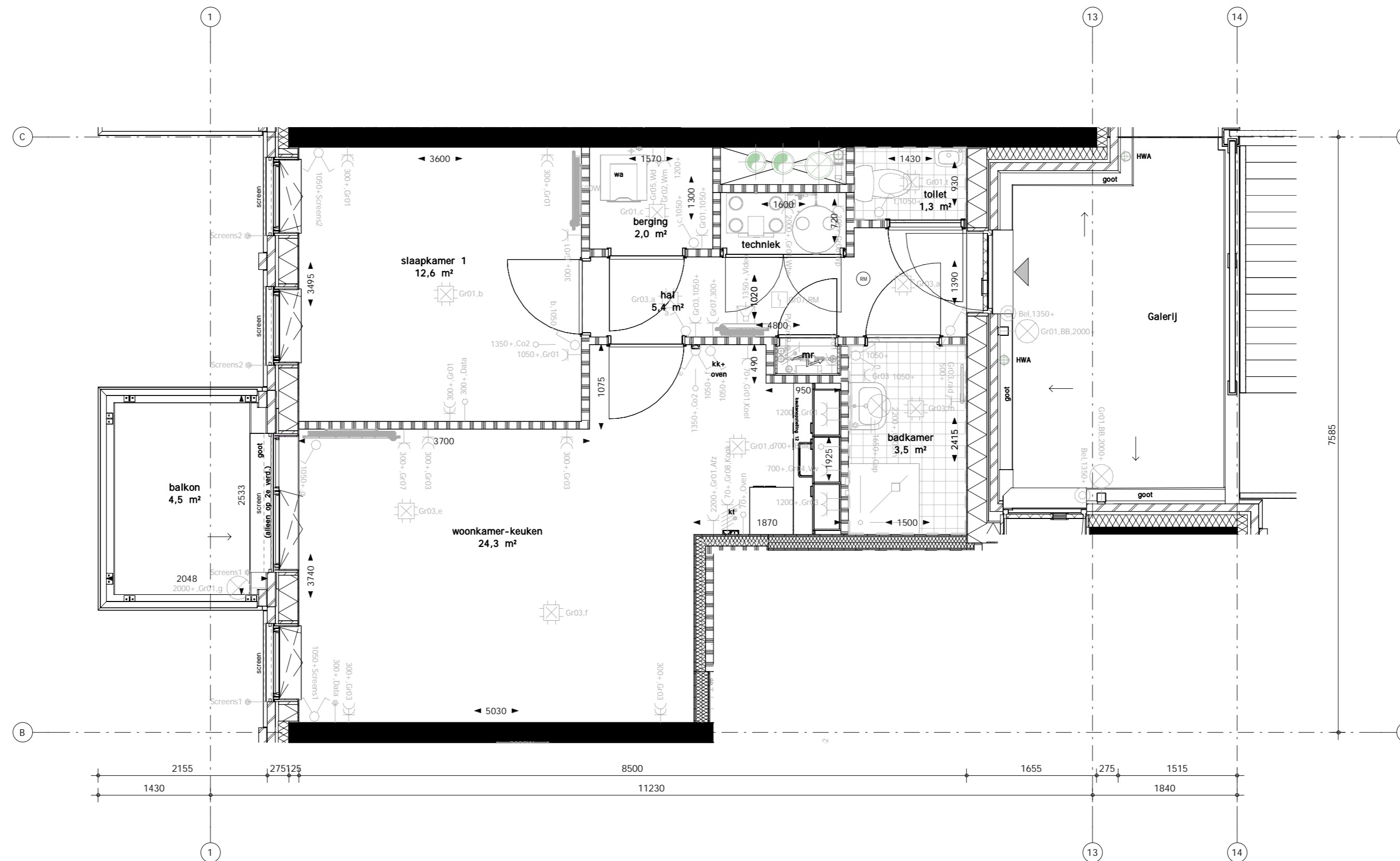

Begane grond

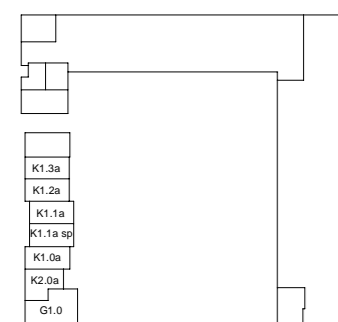

1e verdieping

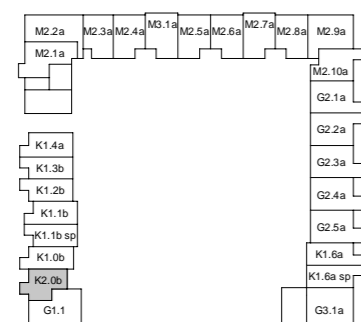

2e verdieping

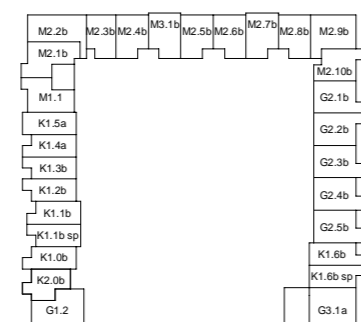

3e verdieping

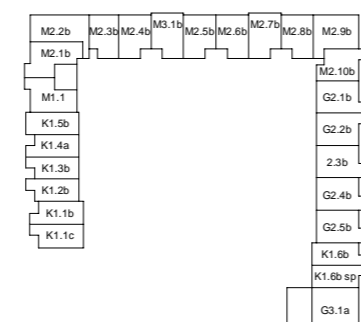

4e verdieping

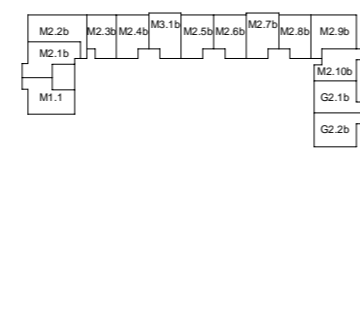

5e verdieping

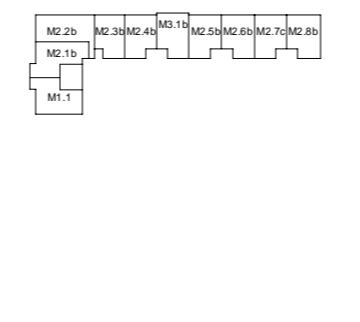

6e verdieping

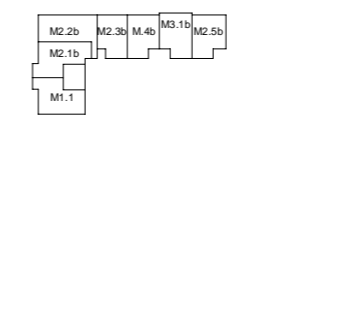

Bnr. 009

120 Appartementen Woerden Snellerpoort B1 "DE WAAG"

Woningtype K2.0b (GO 53,0-m2)

PROJECTNR. : 221239
DATUM : 19-02-2024

SCHAAL : 1:50
FORMAAT : A2
TEKENINGNUMMER : WT-19

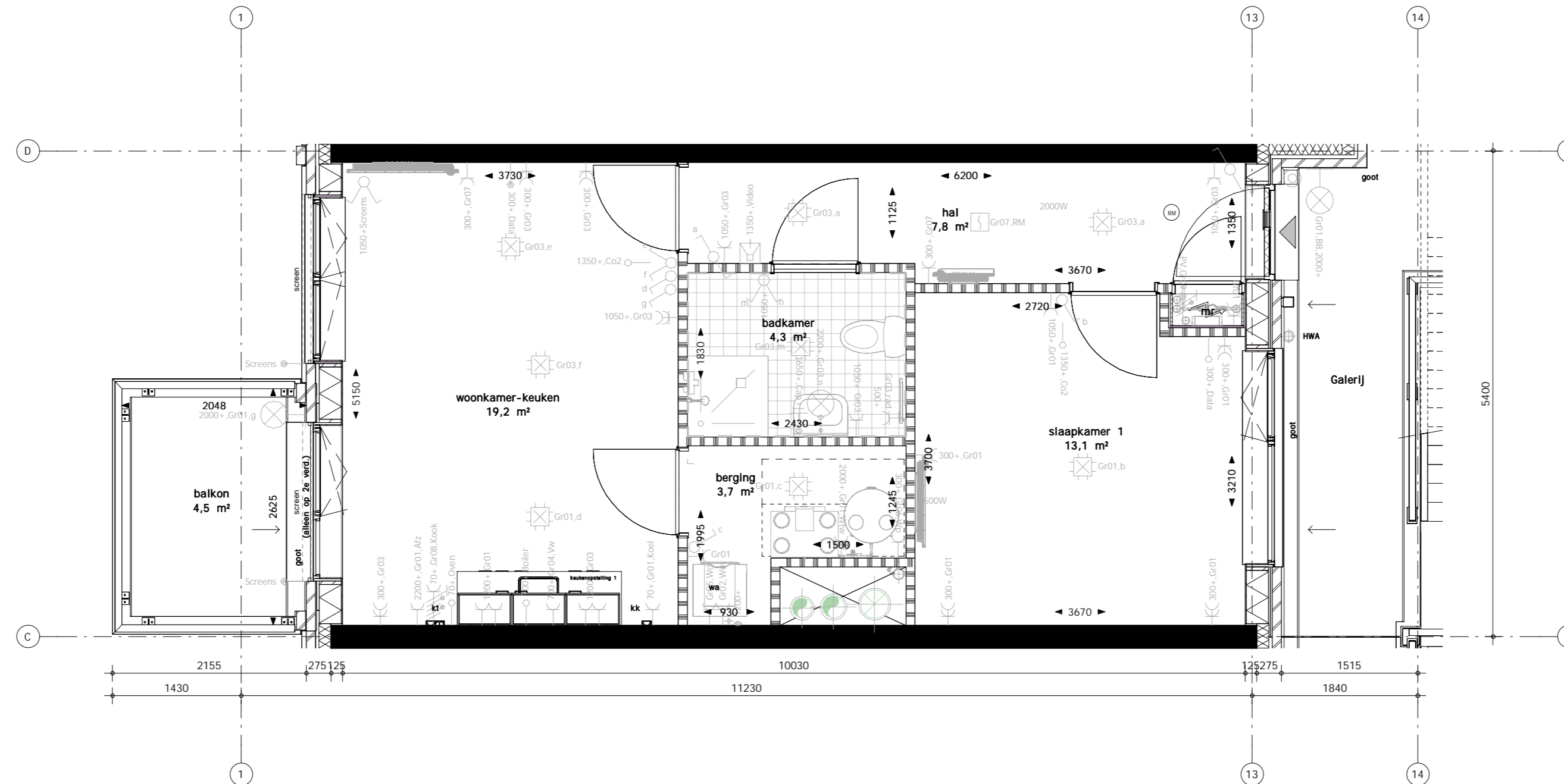

Begane grond

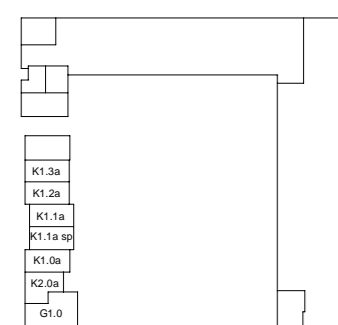

1e verdieping

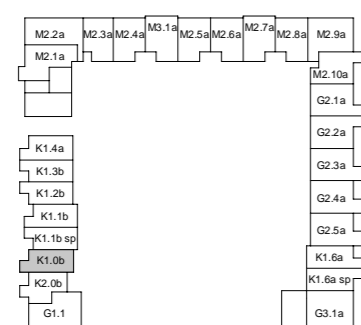

2e verdieping

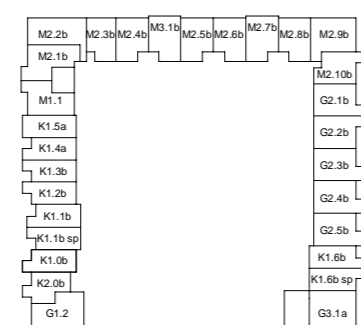

3e verdieping

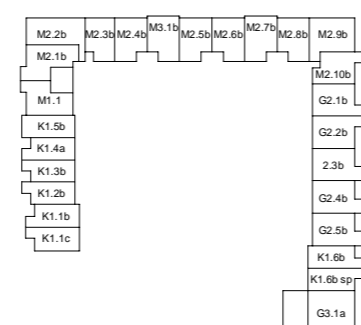

4e verdieping

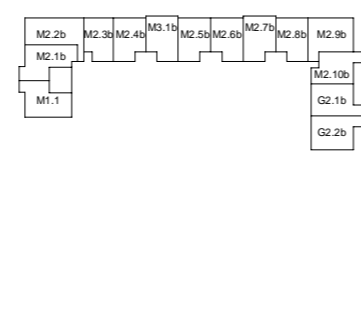

5e verdieping

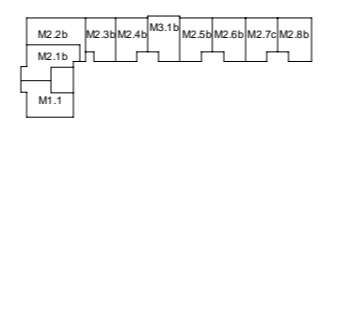

6e verdieping

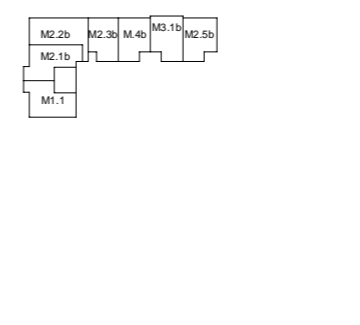

Bnr. 010

120 Appartementen Woerden Snellerpoort B1 "DE WAAG"

Woningtype K1.0b (GO 50,5m2)

PROJECTNR. : 221239
 DATUM : 19-02-2024

SCHAAL : 1:50
 FORMAAT : A2
 TEKENINGNUMMER : WT-05

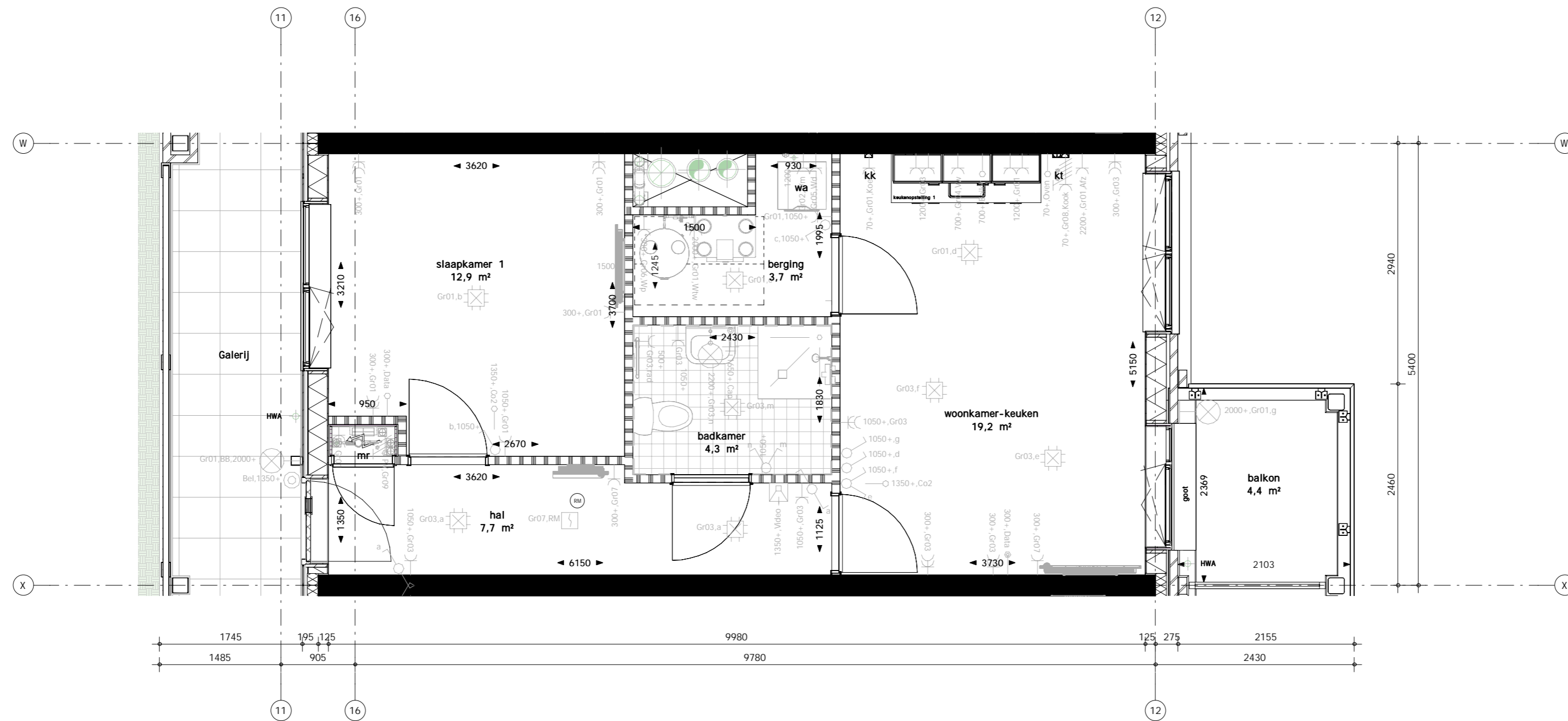

Begane grond

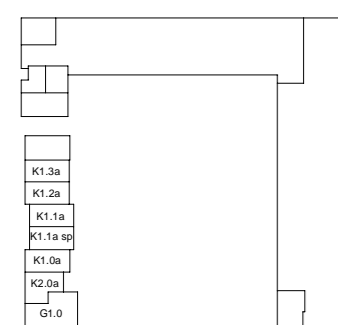

1e verdieping

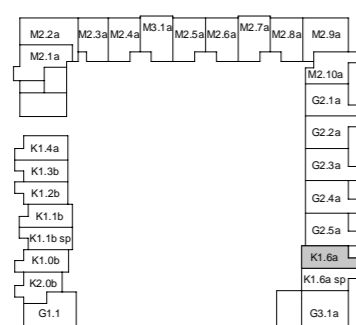

2e verdieping

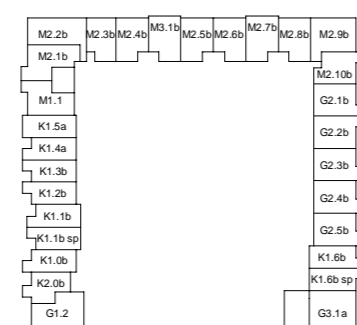

3e verdieping

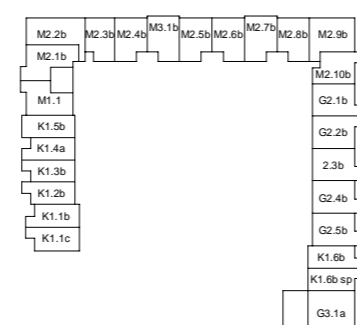

4e verdieping

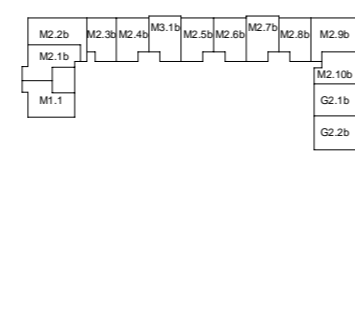

5e verdieping

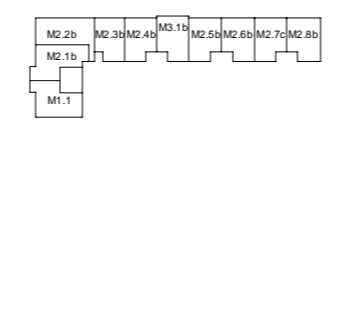

6e verdieping

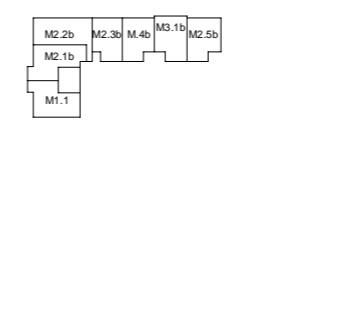

Bnr. 032

120 Appartementen Woerden Snellerpoort B1 "DE WAAG"

Woningtype K1.6a (GO 50,2m2)

PROJECTNR. : 221239
 DATUM : 19-02-2024

SCHAAL : 1:50
 FORMAAT : A2
 TEKENINGNUMMER : WT-55

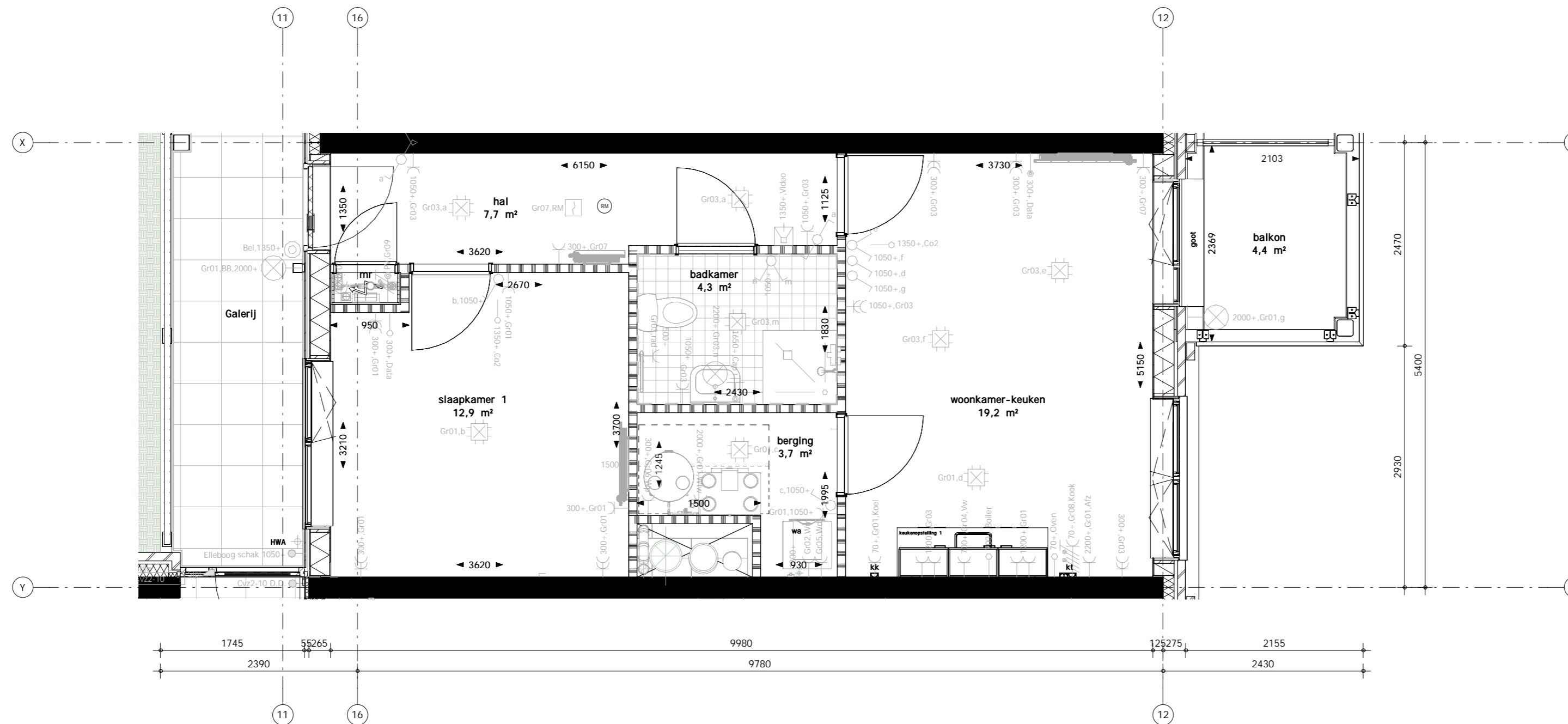

Begane grond

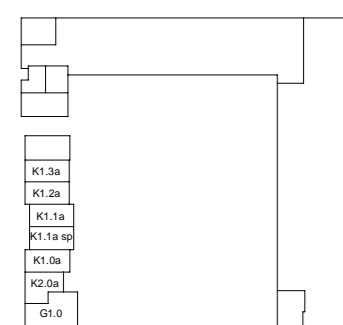

1e verdieping

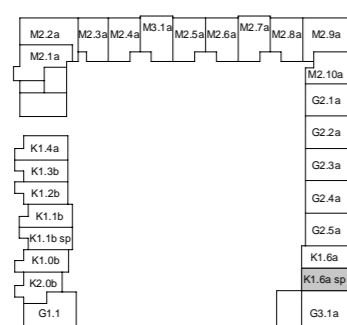

2e verdieping

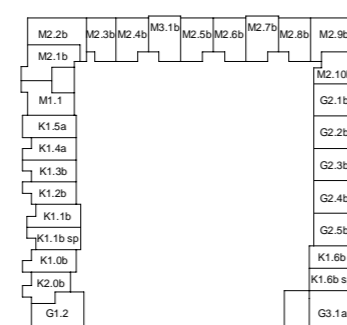

3e verdieping

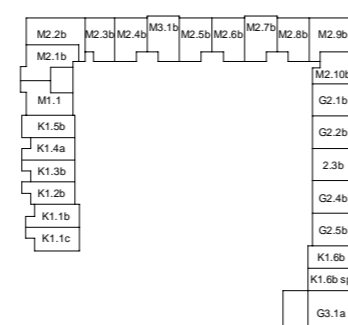

4e verdieping

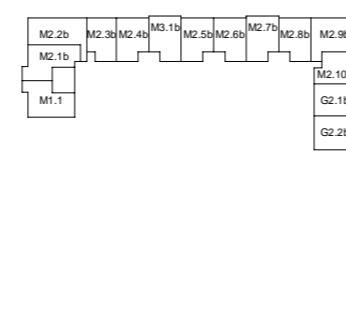

5e verdieping

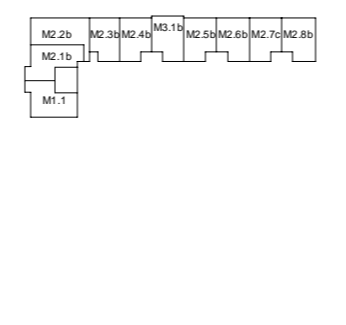

6e verdieping

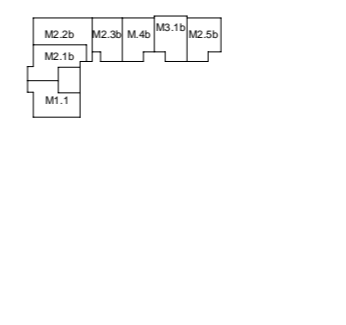

Bnr. 033

120 Appartementen Woerden Snellerpoort B1 "DE
 WAAG"

Woningtype K1.6asp (GO 50,2m2)

PROJECTNR. : 221239
 DATUM : 19-02-2024

SCHAAL : 1:50
 FORMAAT : A2
 TEKENINGNUMMER : WT-56

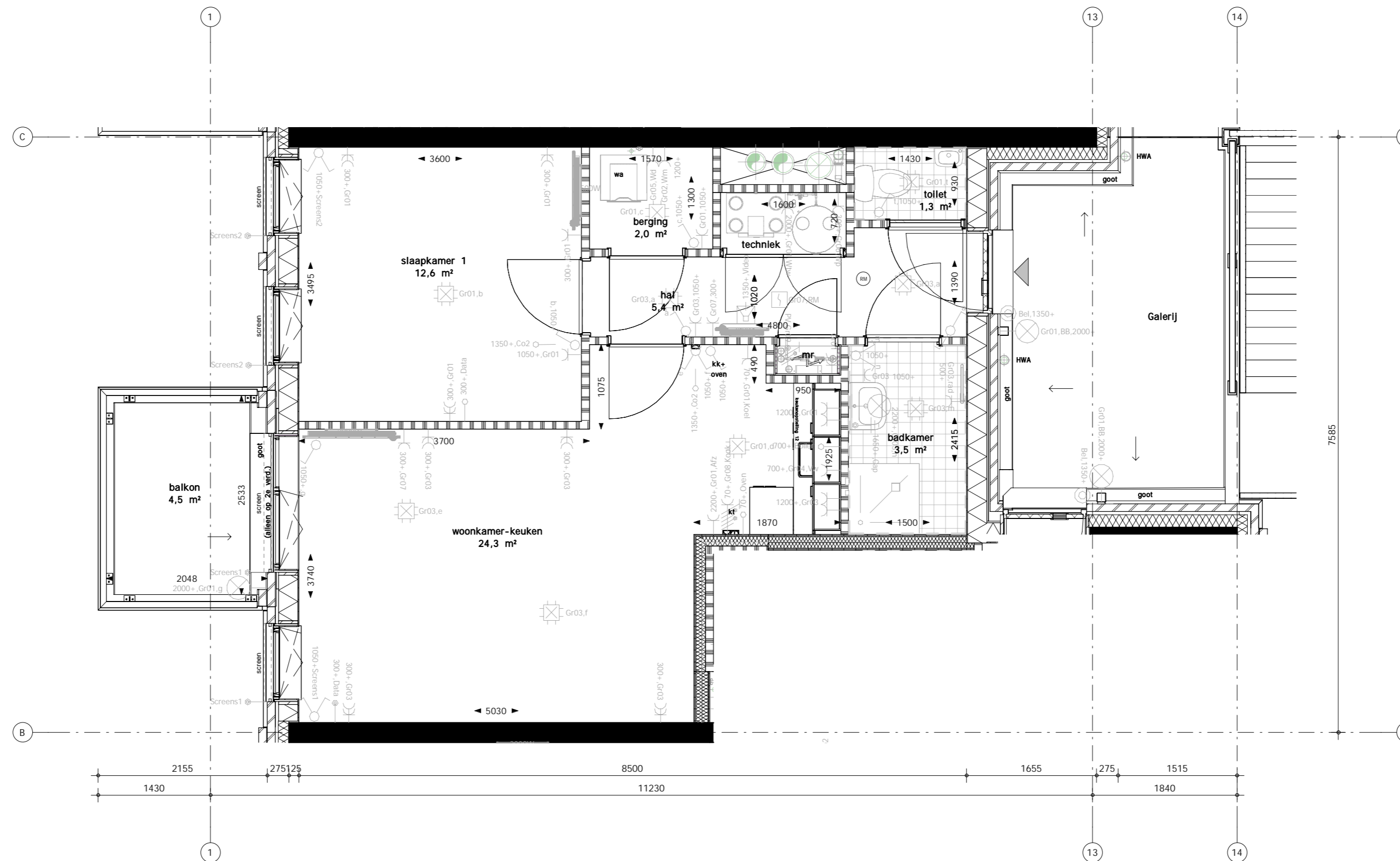

Begane grond

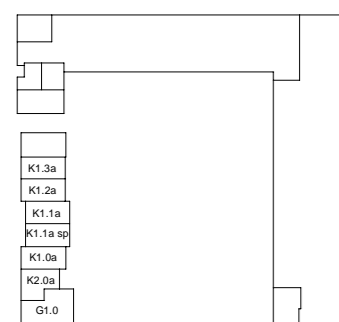

1e verdieping

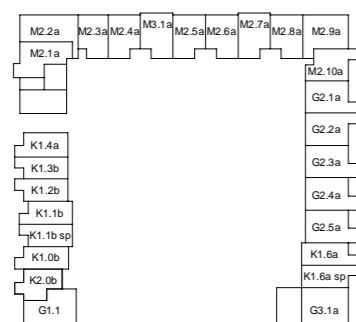

2e verdieping

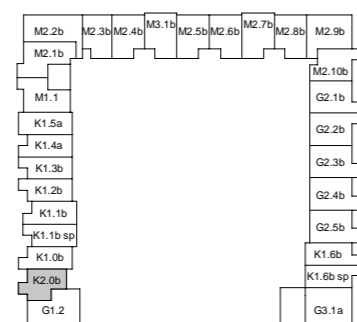

3e verdieping

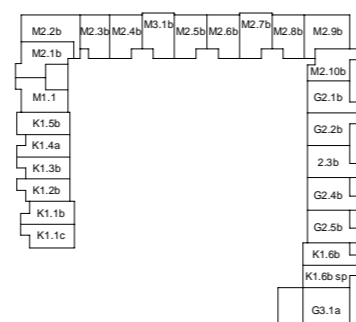

4e verdieping

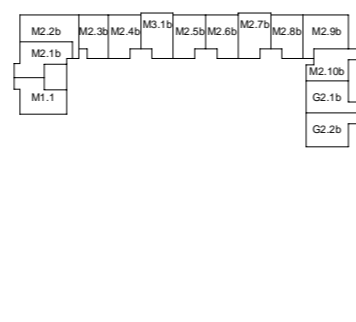

5e verdieping

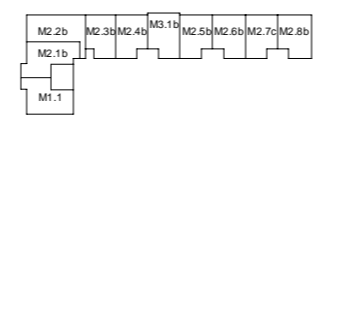

6e verdieping

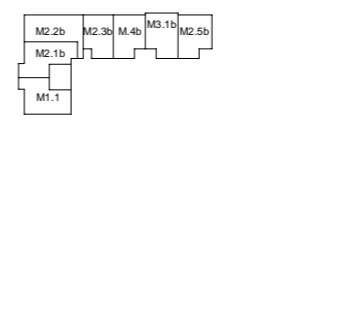

Bnr. 036

120 Appartementen Woerden Snellerpoort B1 "DE WAAG"

Woningtype K2.0b (GO 53,0-m2)

PROJECTNR. : 221239
 DATUM : 19-02-2024

SCHAAL : 1:50
 FORMAAT : A2
 TEKENINGNUMMER : WT-19

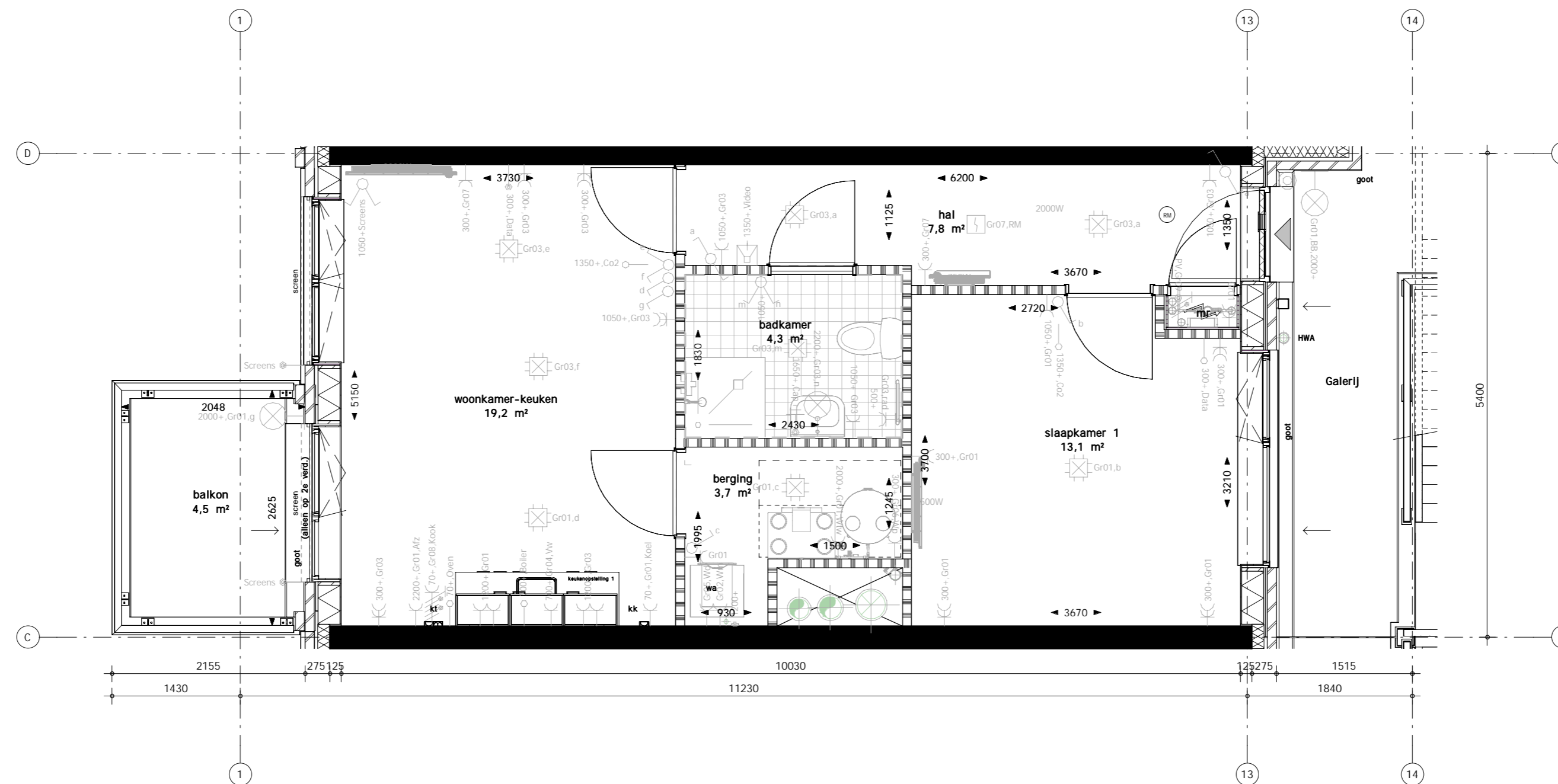

Begane grond

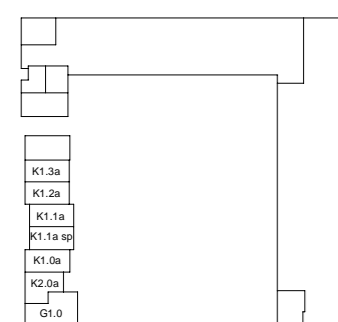

1e verdieping

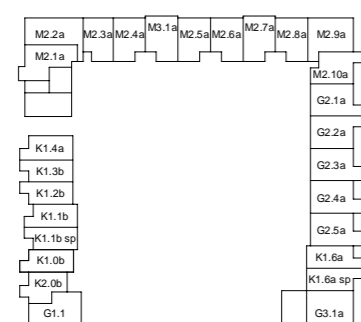

2e verdieping

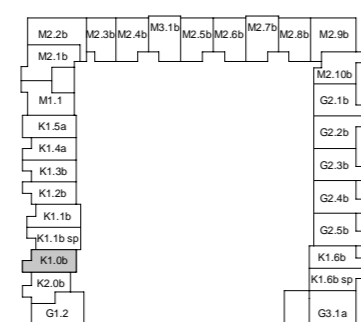

3e verdieping

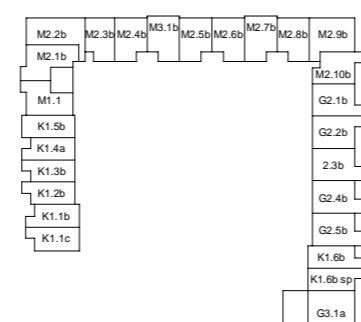

4e verdieping

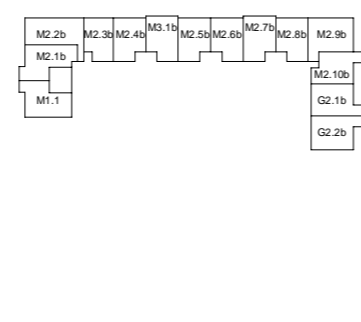

5e verdieping

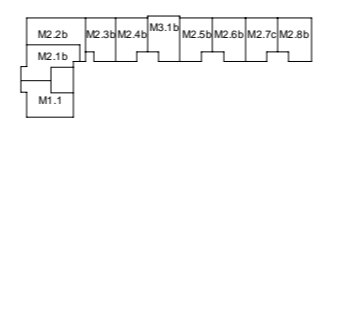

6e verdieping

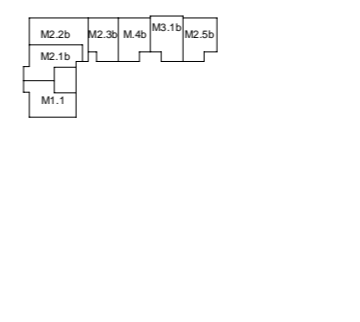

Bnr. 037

120 Appartementen Woerden Snellerpoort B1 "DE WAAG"

Woningtype K1.0b (GO 50,5m2)

PROJECTNR. : 221239
 DATUM : 19-02-2024

SCHAAL : 1:50
 FORMAAT : A2
 TEKENINGNUMMER : WT-05

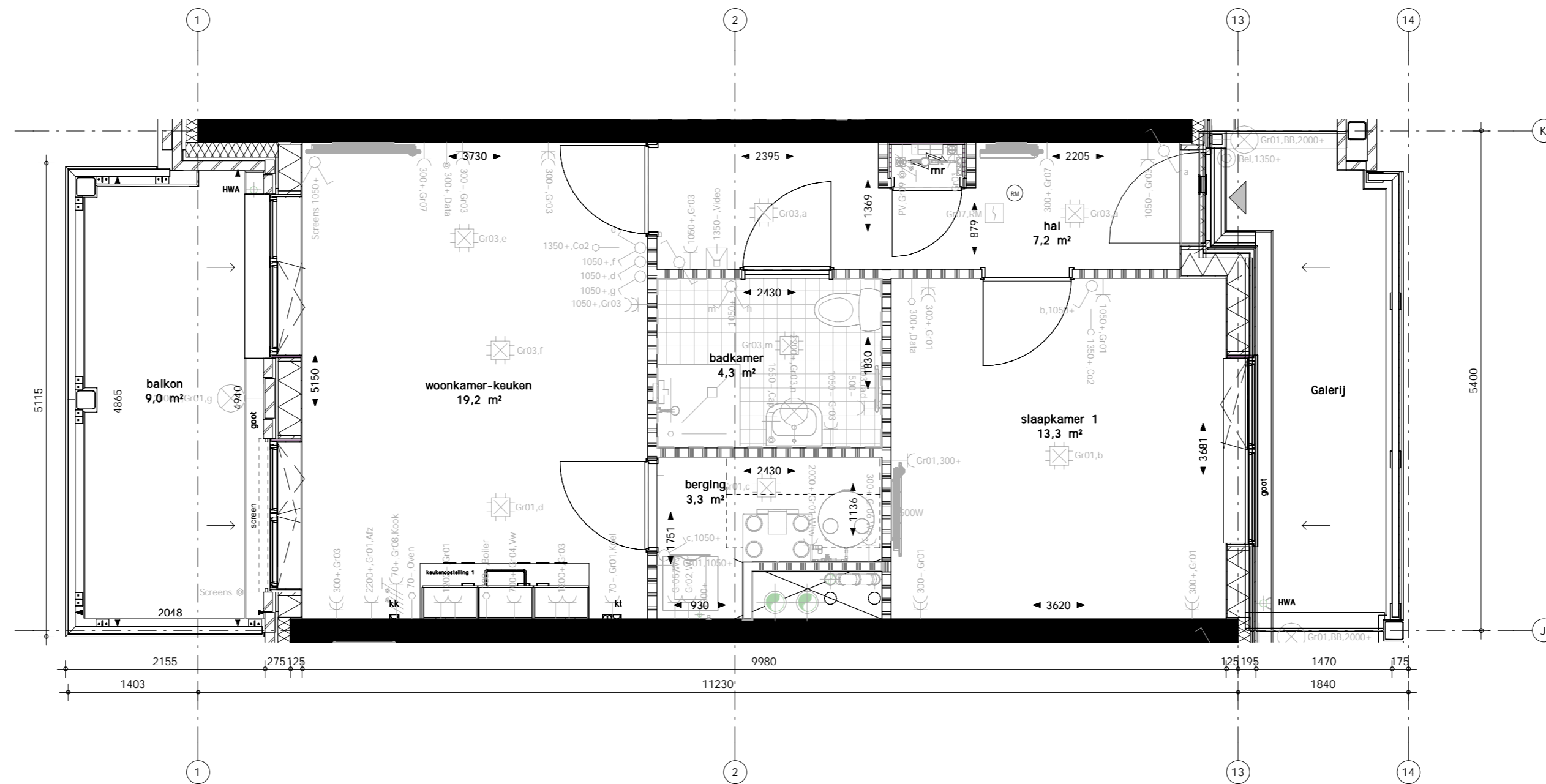

Begane grond

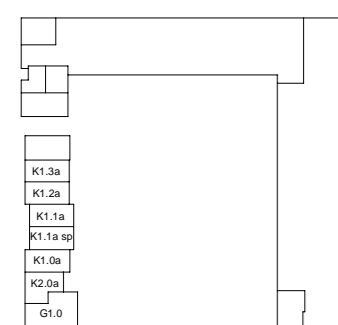

1e verdieping

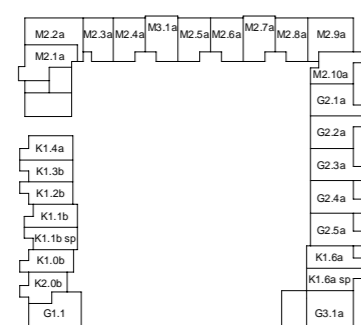

2e verdieping

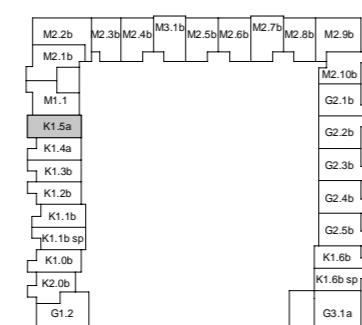

3e verdieping

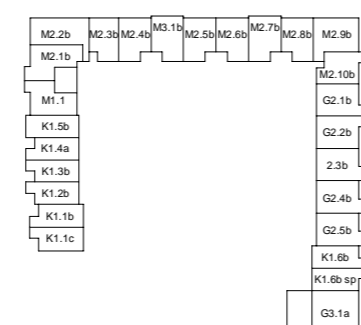

4e verdieping

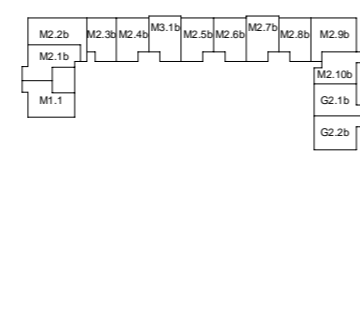

5e verdieping

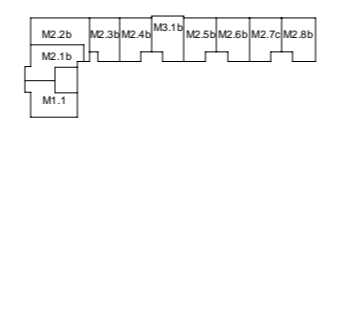

6e verdieping

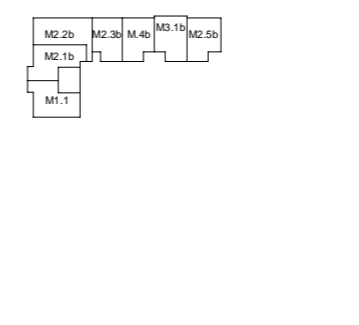

Bnr. 043

120 Appartementen Woerden Snellerpoort B1 "DE WAAG"

Woningtype K1.5a (GO 49,7m2)

PROJECTNR. : 221239
 DATUM : 19-02-2024

SCHAAL : 1:50
 FORMAAT : A2
 TEKENINGNUMMER : WT-16

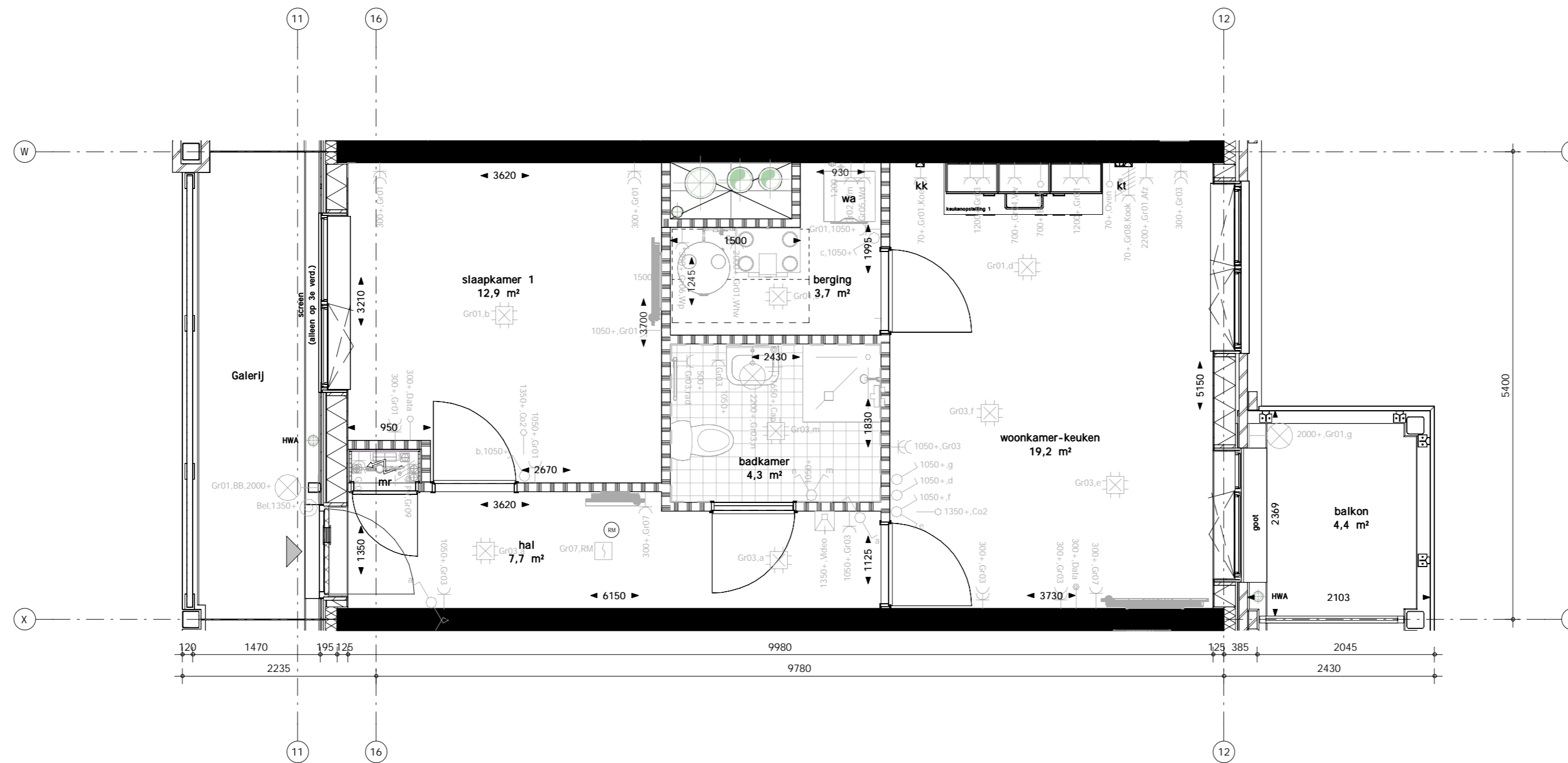

Begane grond

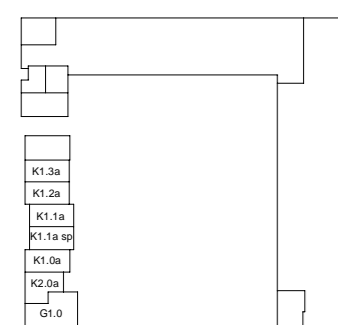

1e verdieping

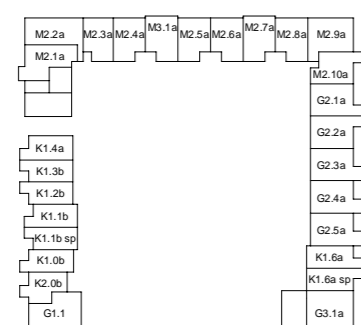

2e verdieping

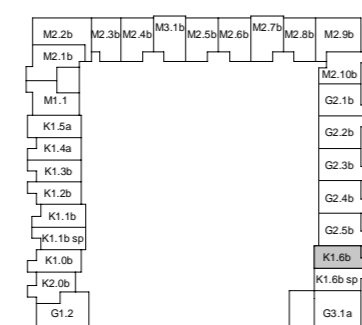

3e verdieping

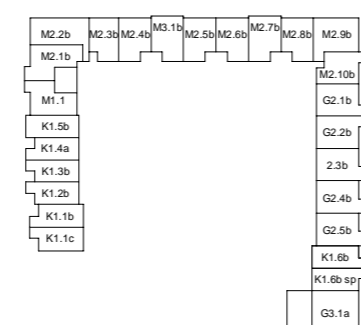

4e verdieping

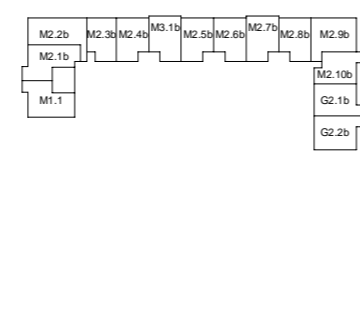

5e verdieping

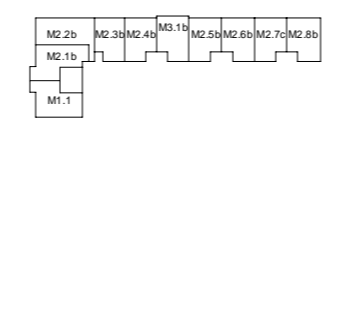

6e verdieping

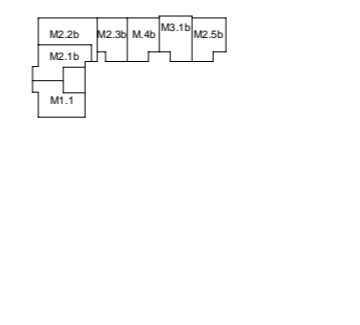

Bnr. 061

120 Appartementen Woerden Snellerpoort B1 "DE
 WAAG"

Woningtype K1.6b (GO 50,2m2)

PROJECTNR. : 221239
 DATUM : 19-02-2024

SCHAAL : 1:50
 FORMAAT : A2
 TEKENINGNUMMER : WT-57

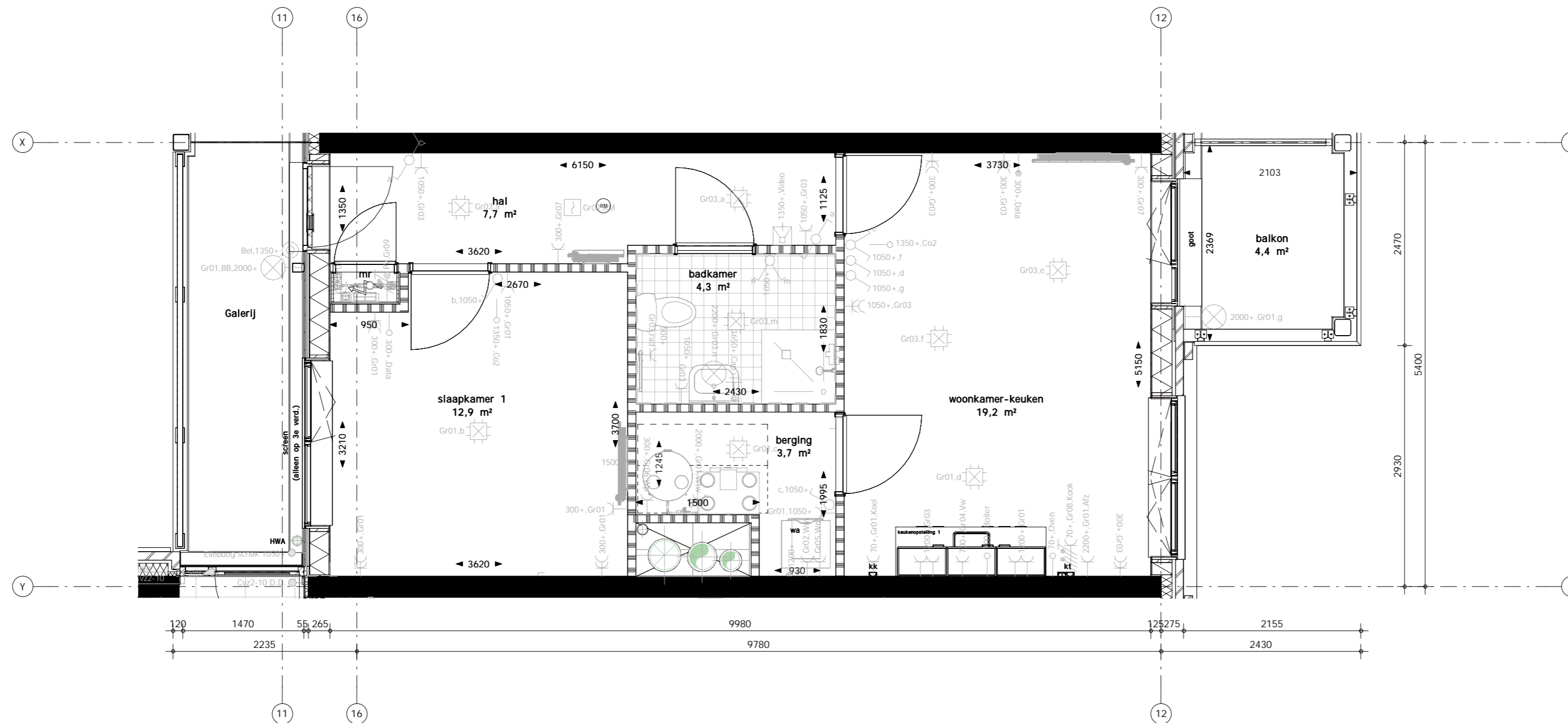

Begane grond

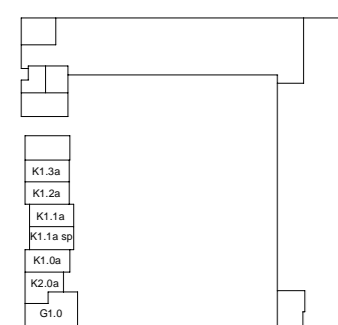

1e verdieping

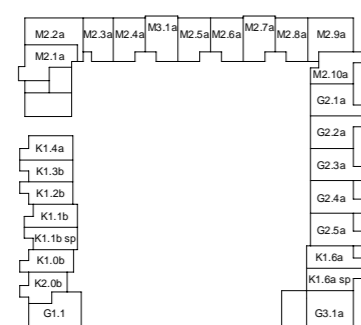

2e verdieping

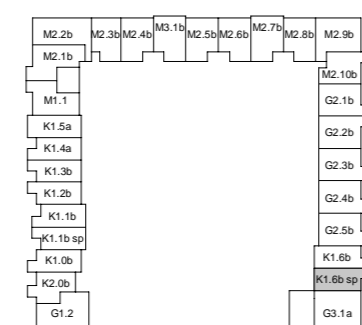

3e verdieping

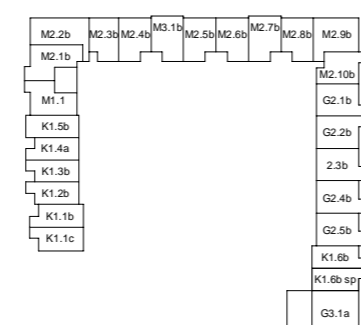

4e verdieping

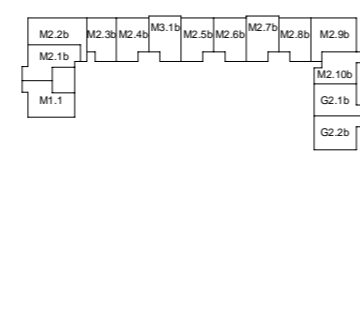

5e verdieping

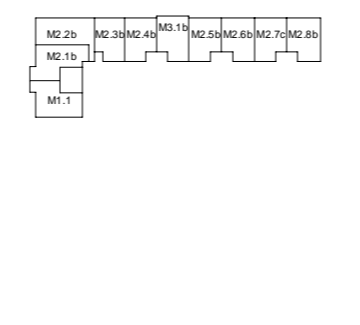

6e verdieping

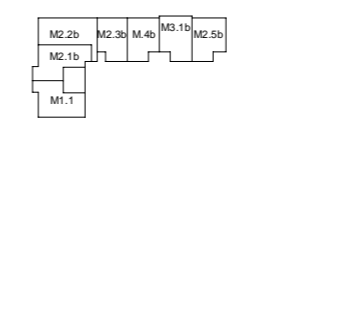

Bnr. 062

120 Appartementen Woerden Snellerpoort B1 "DE
 WAAG"

Woningtype K1.6bsp (GO 50,2m2)

PROJECTNR. : 221239
 DATUM : 19-02-2024

SCHAAL : 1:50
 FORMAAT : A2
 TEKENINGNUMMER : WT-58

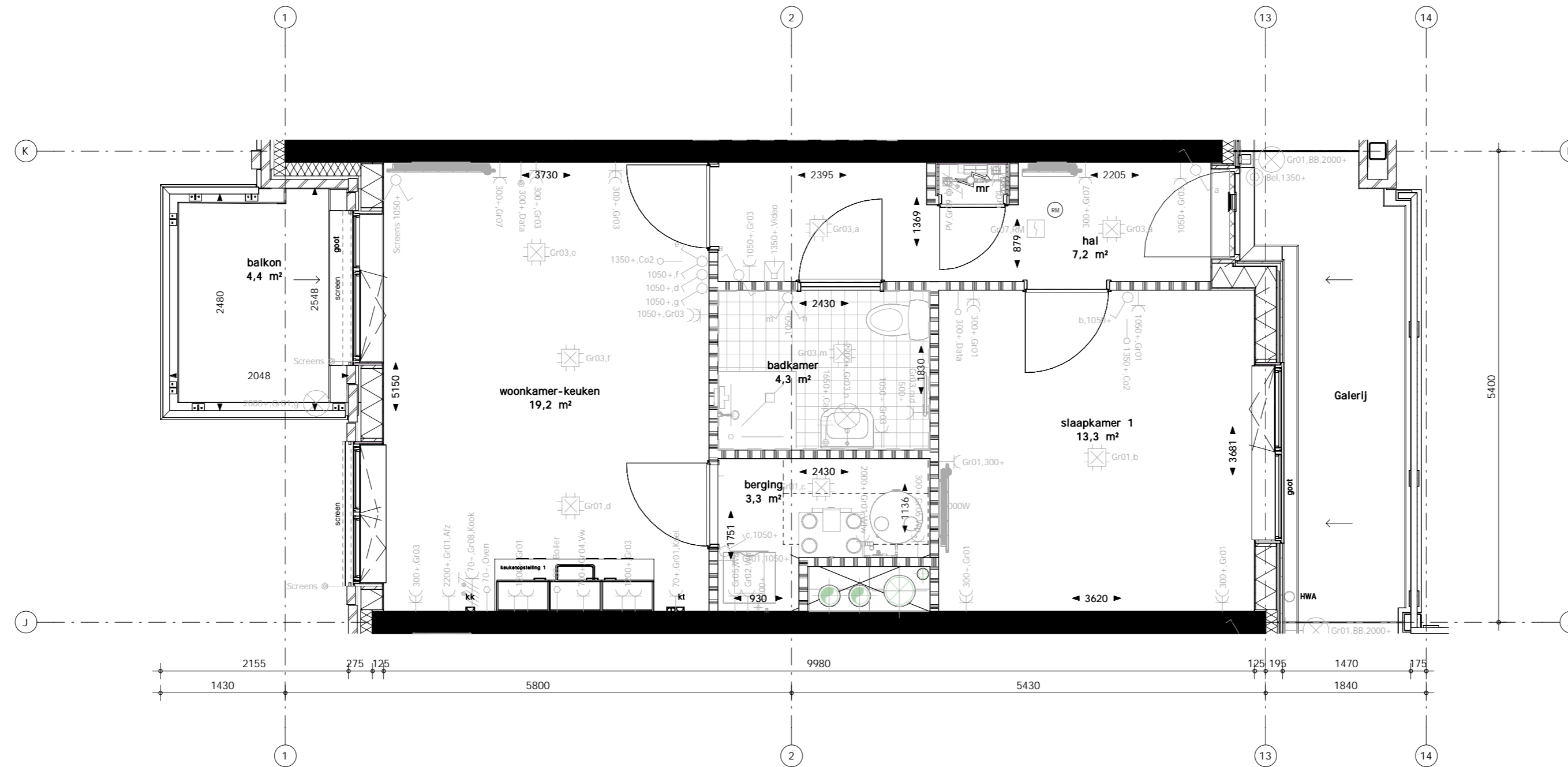

Begane grond

1e verdieping

2e verdieping

3e verdieping

4e verdieping

5e verdieping

6e verdieping

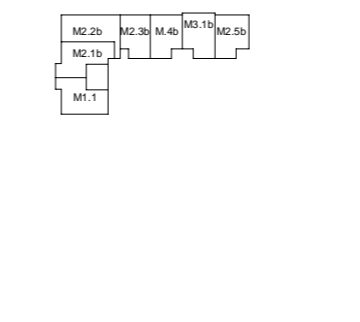
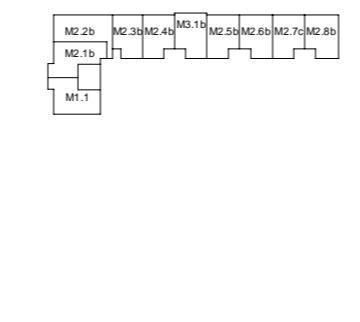
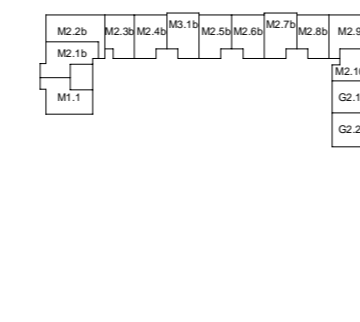
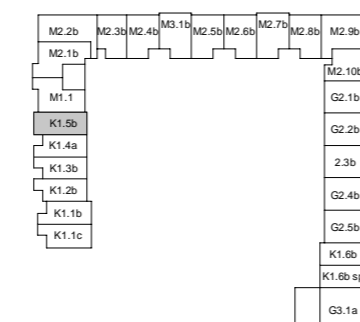
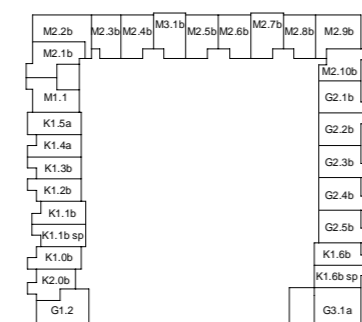
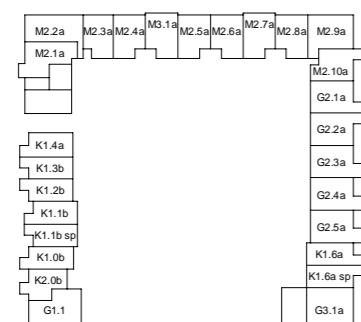
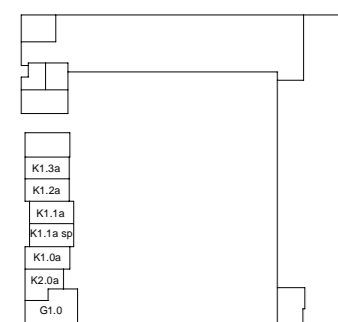

Bnr. 069

120 Appartementen Woerden Snellerpoort B1 "DE
WAAG"

Woningtype K1.5b (GO 49,7m2)

PROJECTNR. : 221239
DATUM : 19-02-2024

SCHAAL : 1:50
FORMAAT : A2
TEKENINGNUMMER : WT-17

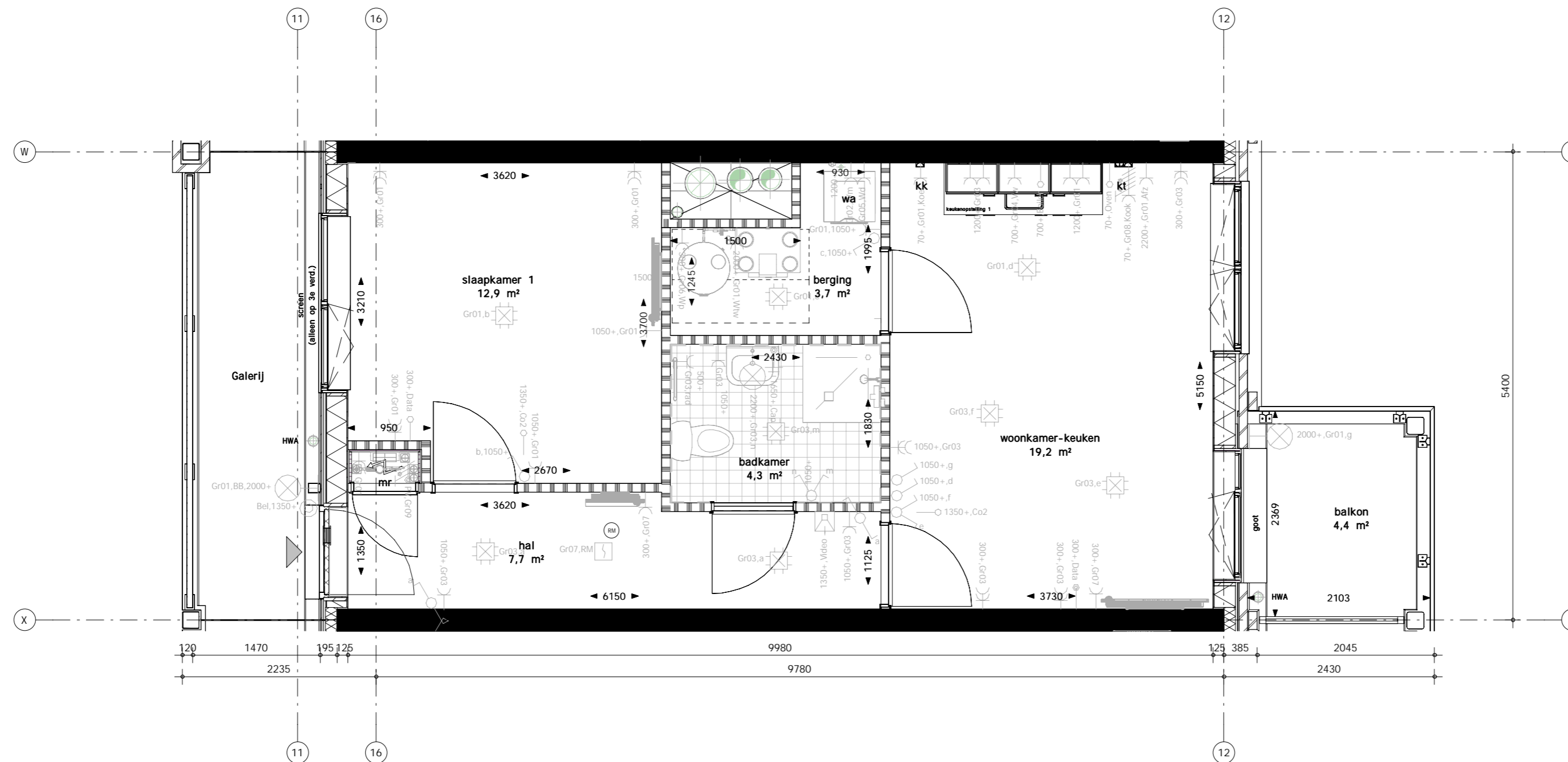

Begane grond

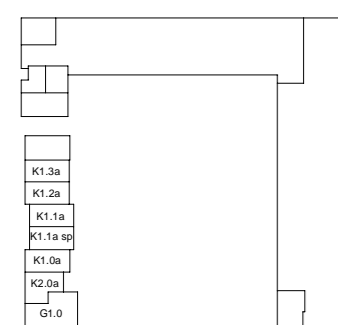

1e verdieping

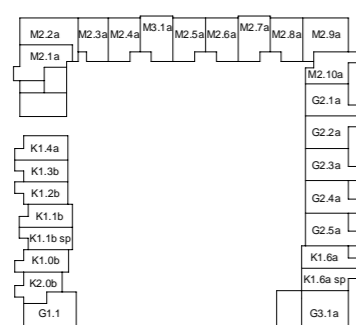

2e verdieping

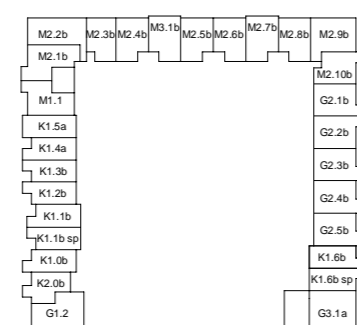

3e verdieping

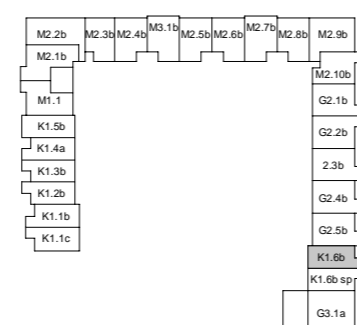

4e verdieping

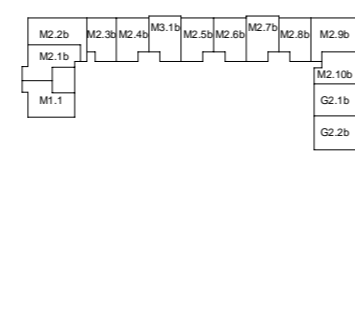

5e verdieping

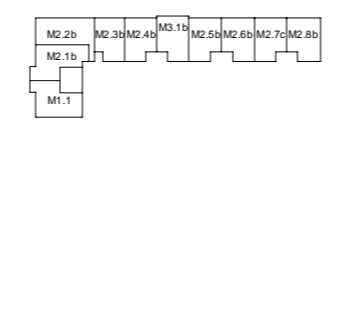

6e verdieping

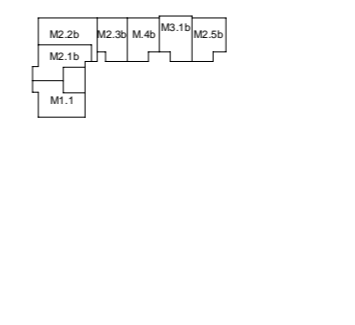

Bnr. 087

120 Appartementen Woerden Snellerpoort B1 "DE
 WAAG"

Woningtype K1.6b (GO 50,2m2)

PROJECTNR. : 221239
 DATUM : 19-02-2024

SCHAAL : 1:50
 FORMAAT : A2
 TEKENINGNUMMER : WT-57

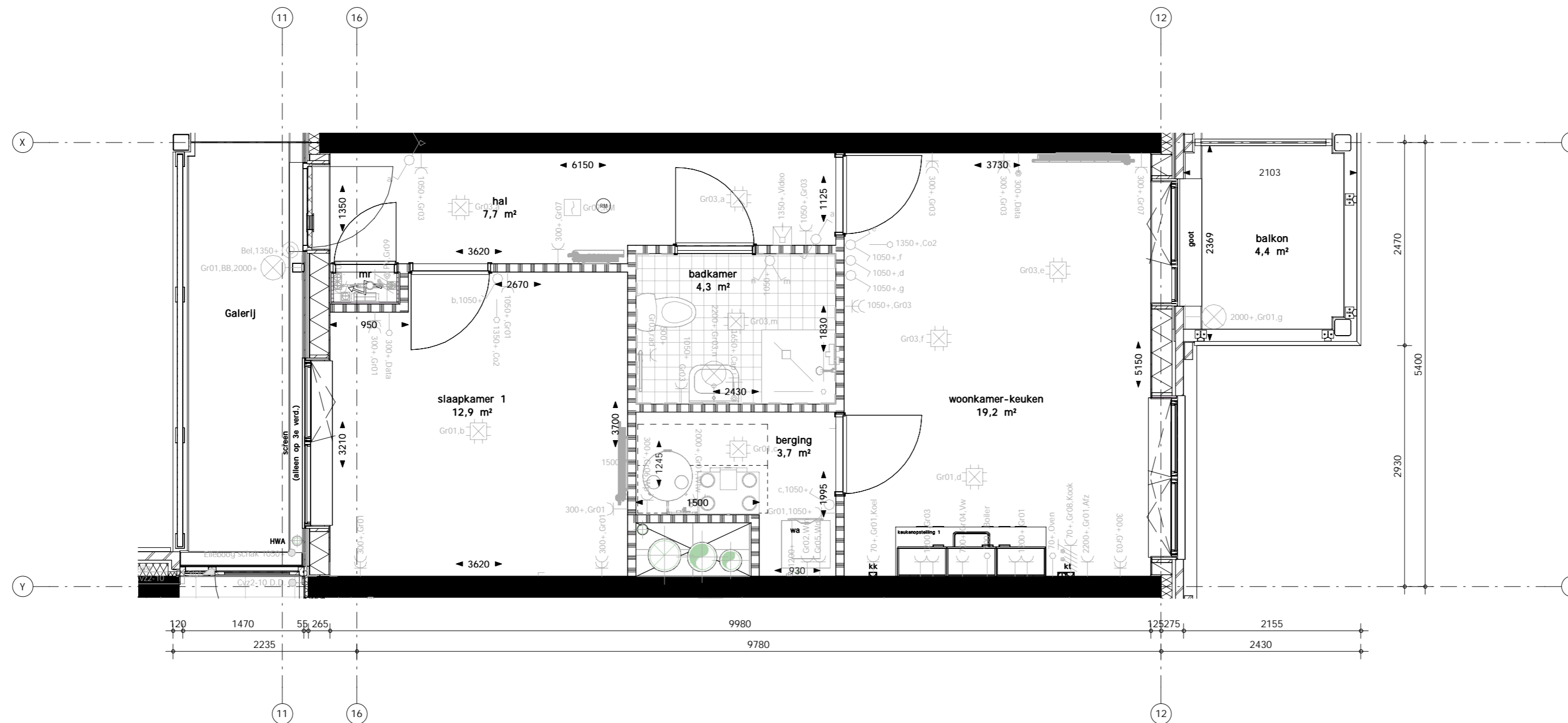

Begane grond

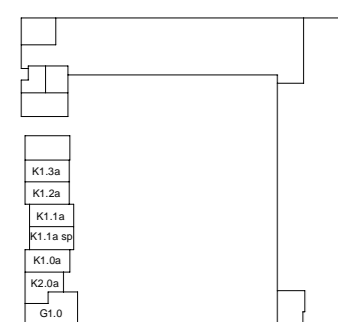

1e verdieping

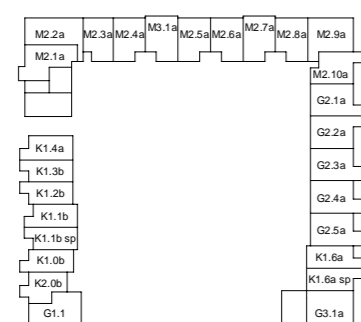

2e verdieping

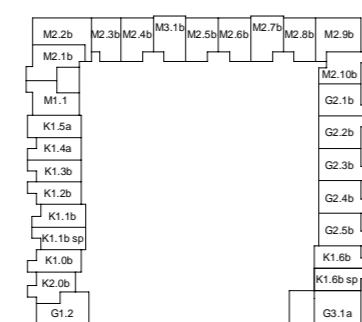

3e verdieping

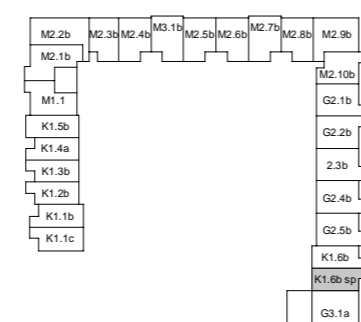

4e verdieping

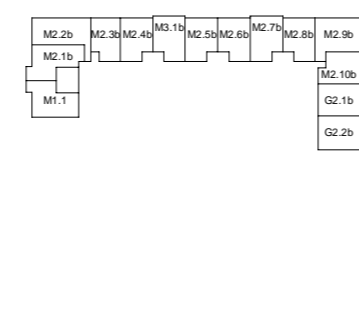

5e verdieping

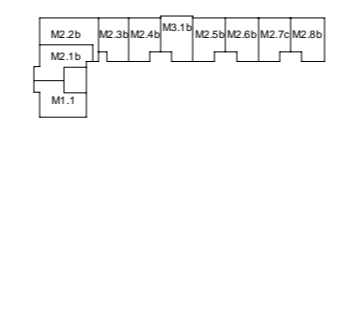

6e verdieping

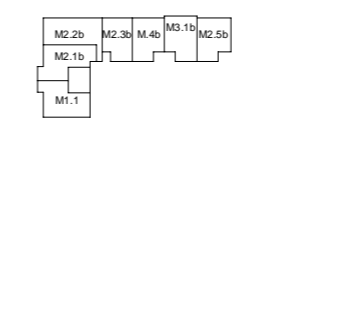

Bnr. 088

120 Appartementen Woerden Snellerpoort B1 "DE
 WAAG"

Woningtype K1.6bsp (GO 50,2m²)

PROJECTNR. : 221239
 DATUM : 19-02-2024

SCHAAL : 1:50
 FORMAAT : A2
 TEKENINGNUMMER : WT-58